

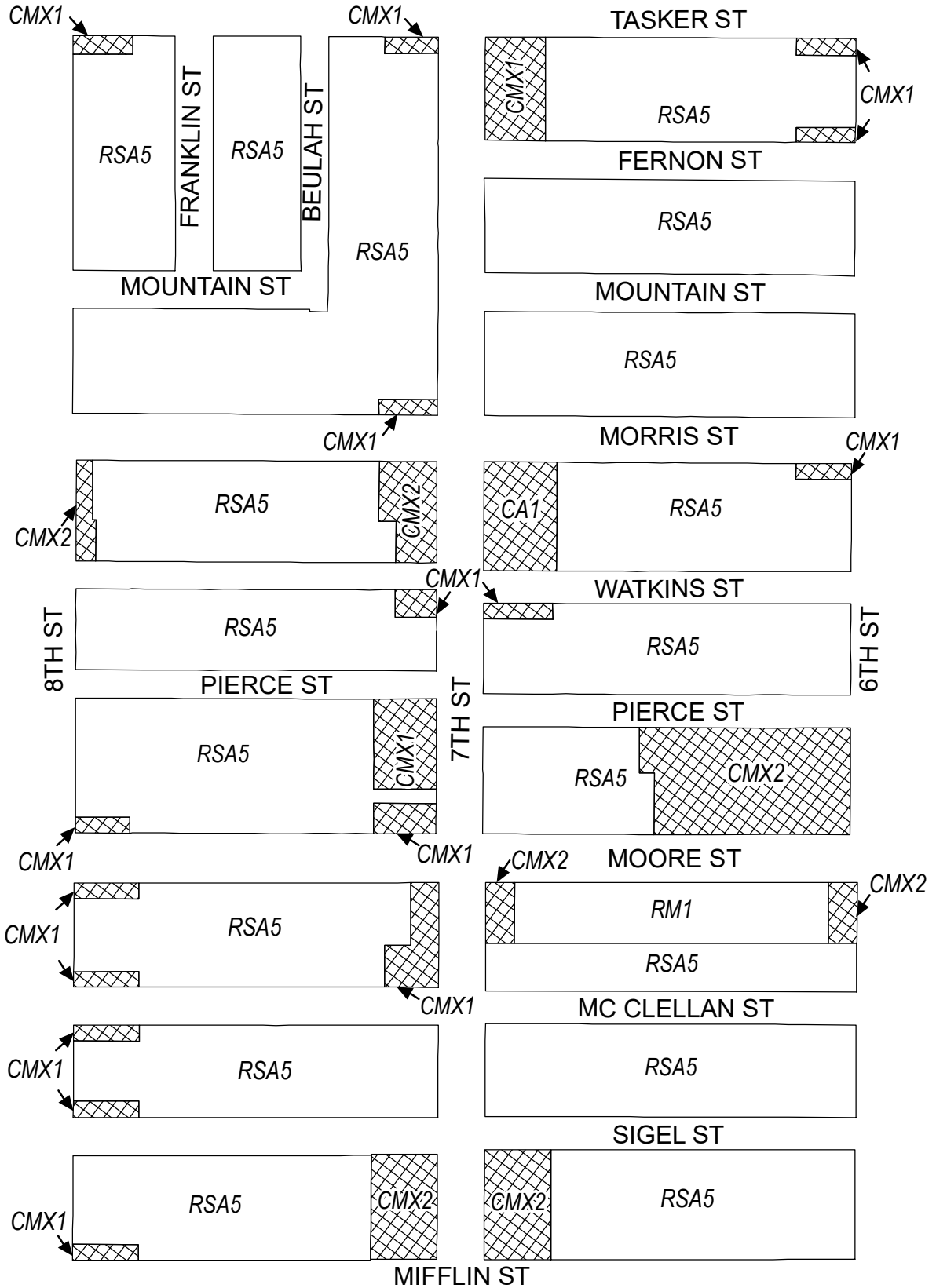

# Map A1 Existing Zoning



## Zoning Districts



-  CA-1, Auto-Oriented Commercial; CMX-1/CMX-2, Commercial Mixed-Use
-  RM-1, Residential Multi-Family; RSA-5, Residential Single-Family Attached

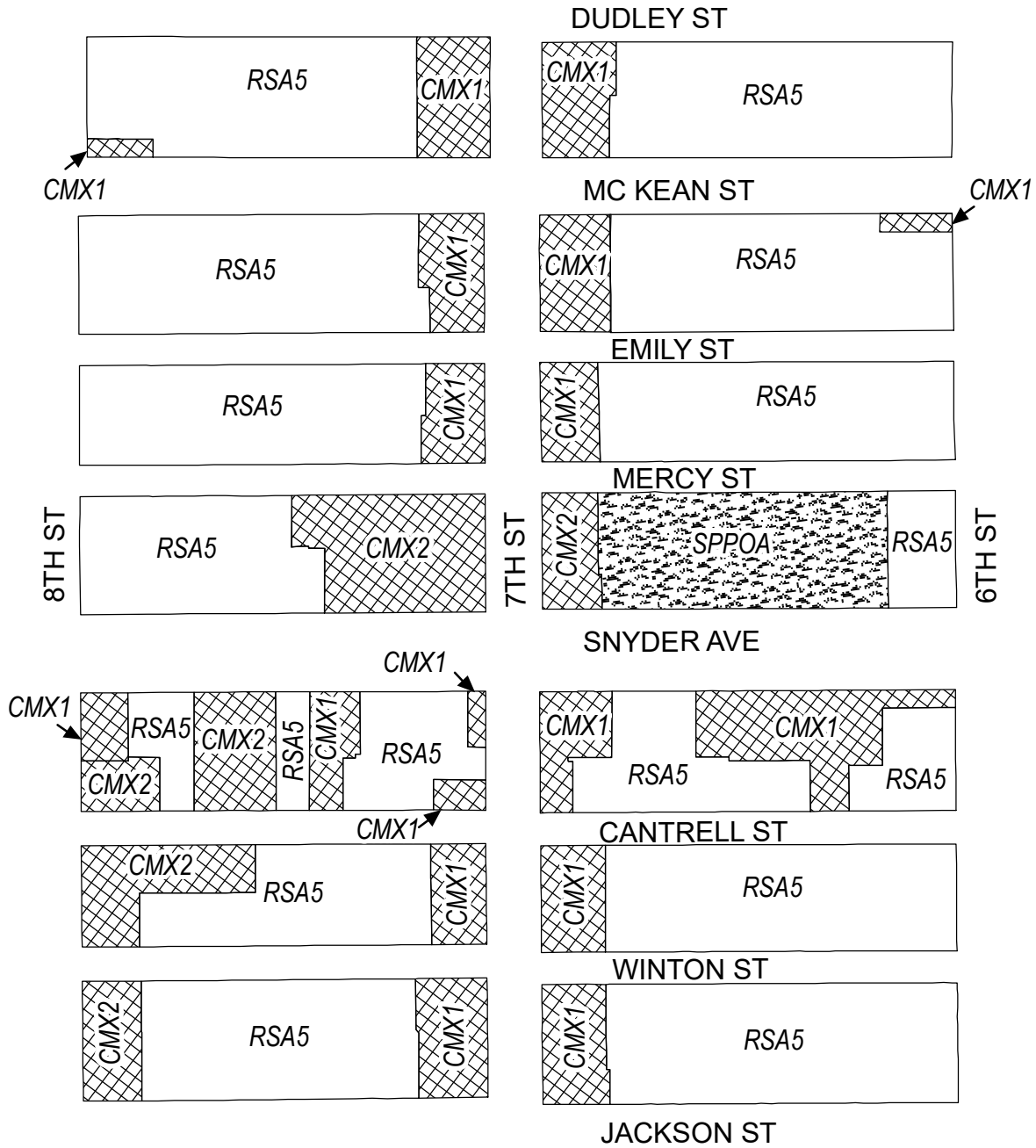

# Map A2 Existing Zoning



## Zoning Districts



-  CMX-1/CMX-2, Commercial Mixed-Use
-  RSA-5, Residential Single-Family Attached
-  SP-PO-A, Special Purpose Open Space

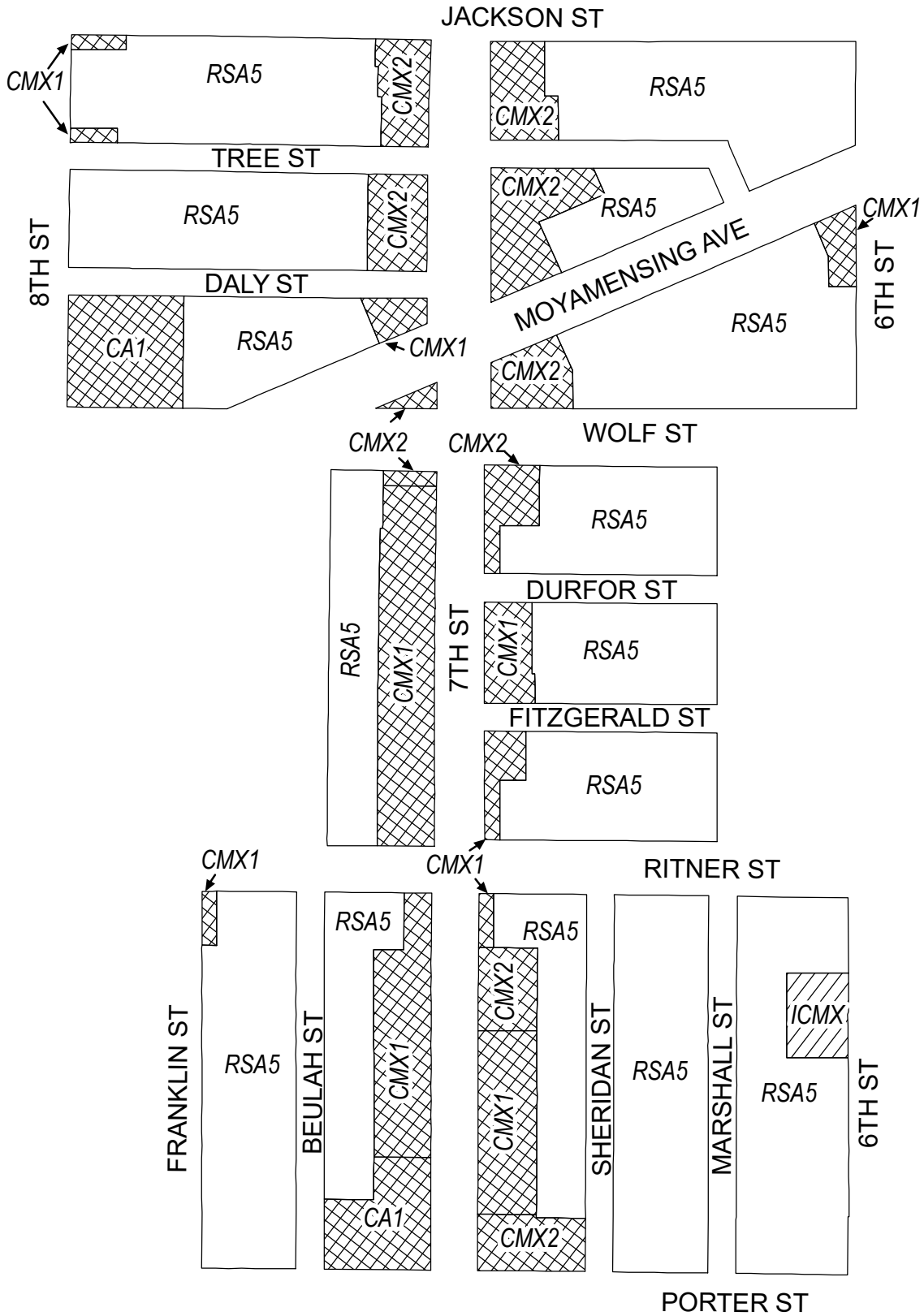

# Map A3 Existing Zoning



## Zoning Districts



-  CA-1, Auto-Oriented Commercial; CMX-1/CMX-2, Commercial Mixed-Use
-  RSA-5, Residential Single-Family Attached
-  ICMX, Industrial Commercial Mixed-Use

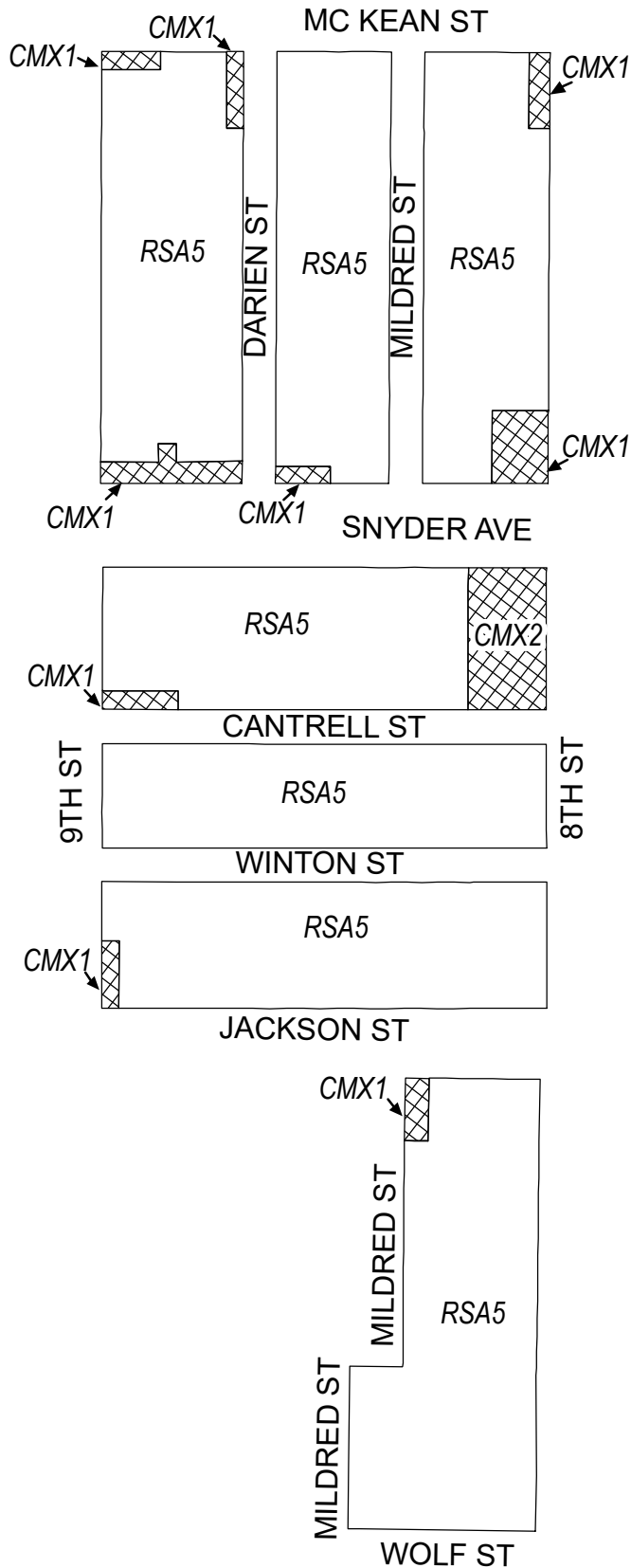

# Map A4 Existing Zoning



## Zoning Districts

-  CMX-1/CMX-2, Commercial Mixed-Use
-  RSA-5, Residential Single-Family Attached



# Map A5 Existing Zoning

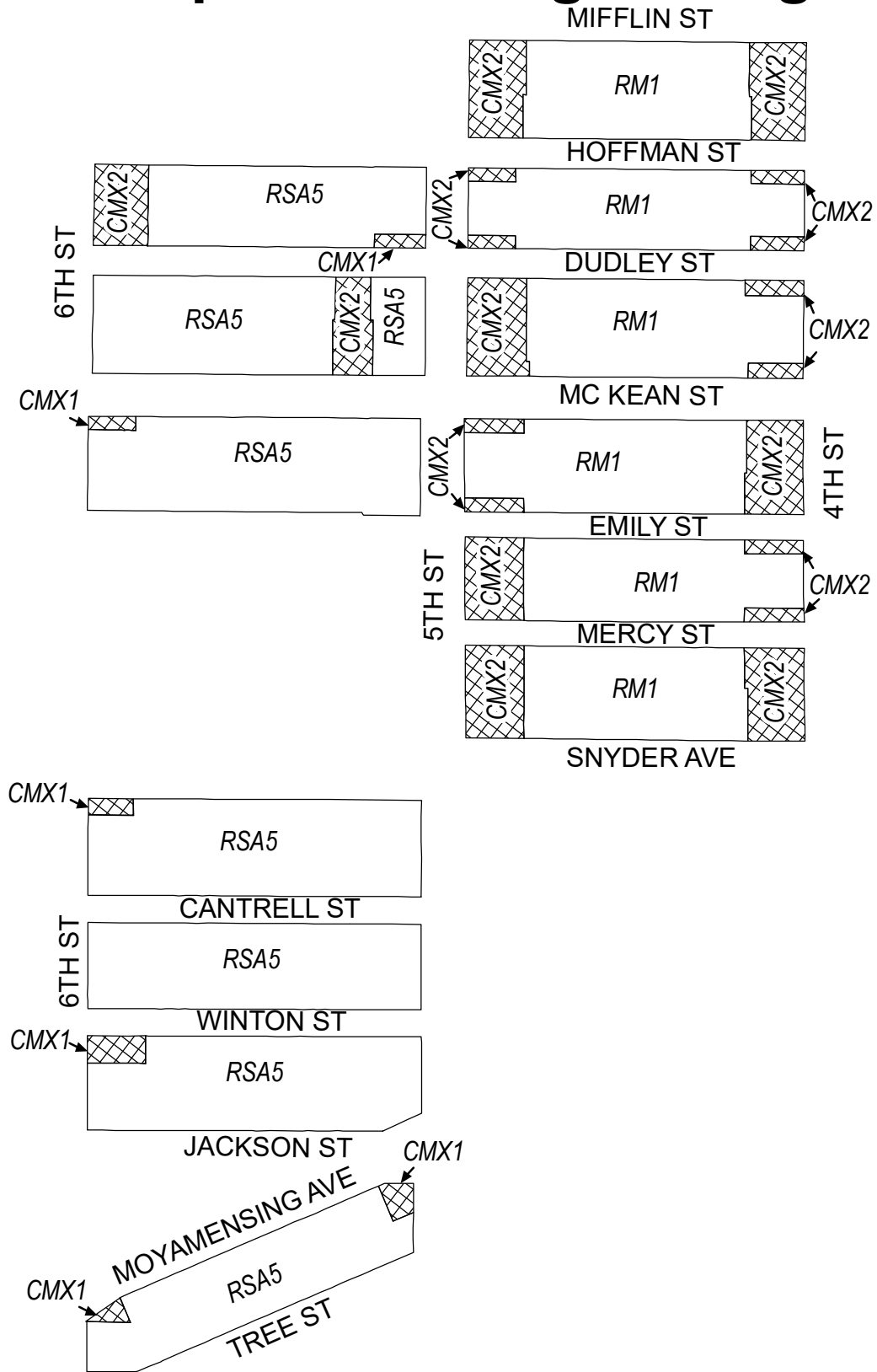

## Zoning Districts

 CMX-1/CMX-2, Commercial Mixed-Use

 RM-1, Residential Multi-Family; RSA-5, Residential Single-Family Attached



# Map B1 Proposed Zoning

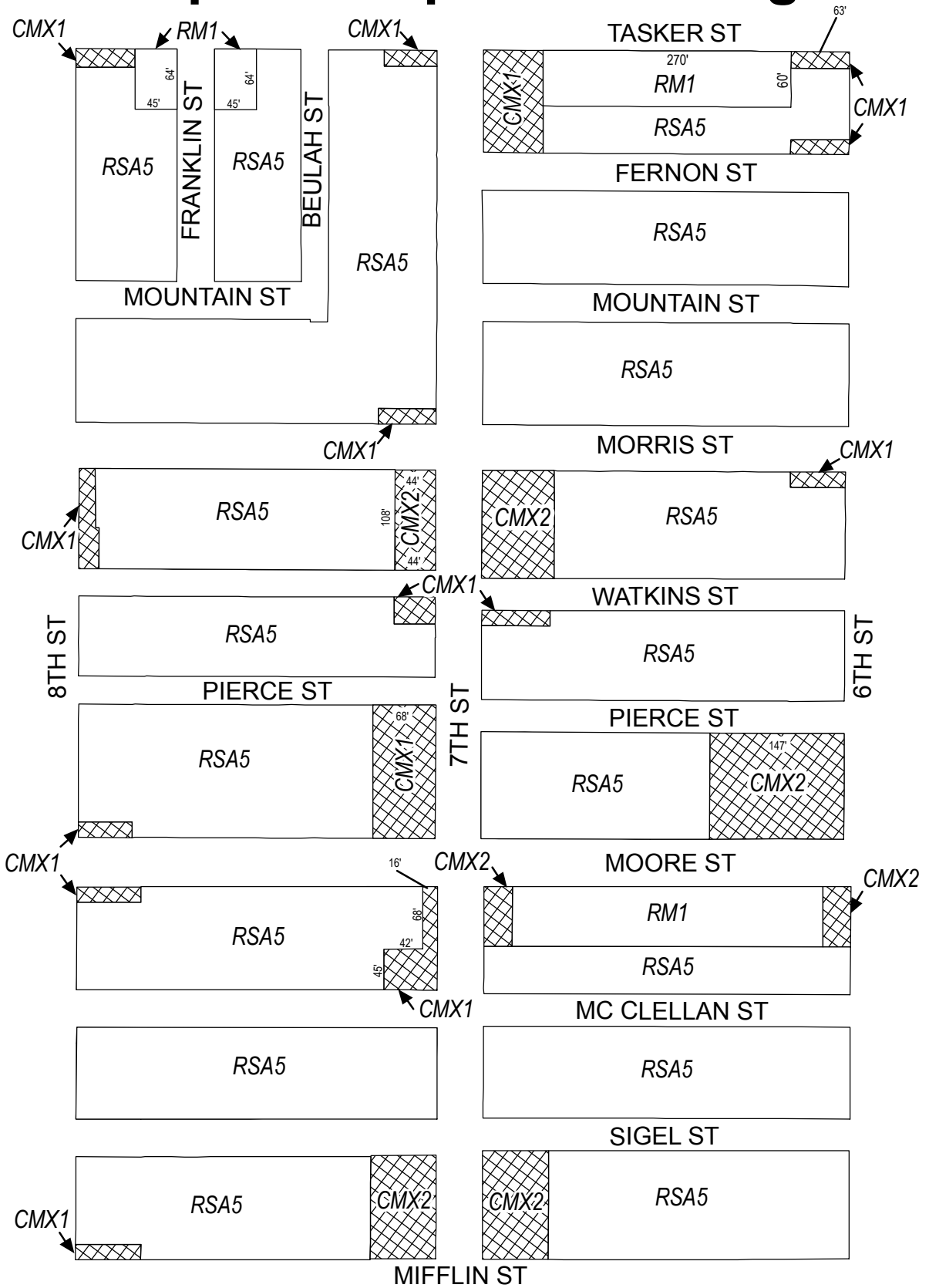

## Zoning Districts

 CMX-1/CMX-2, Commercial Mixed-Use



 RM-1, Residential Multi-Family; RSA-5, Residential Single-Family Attached

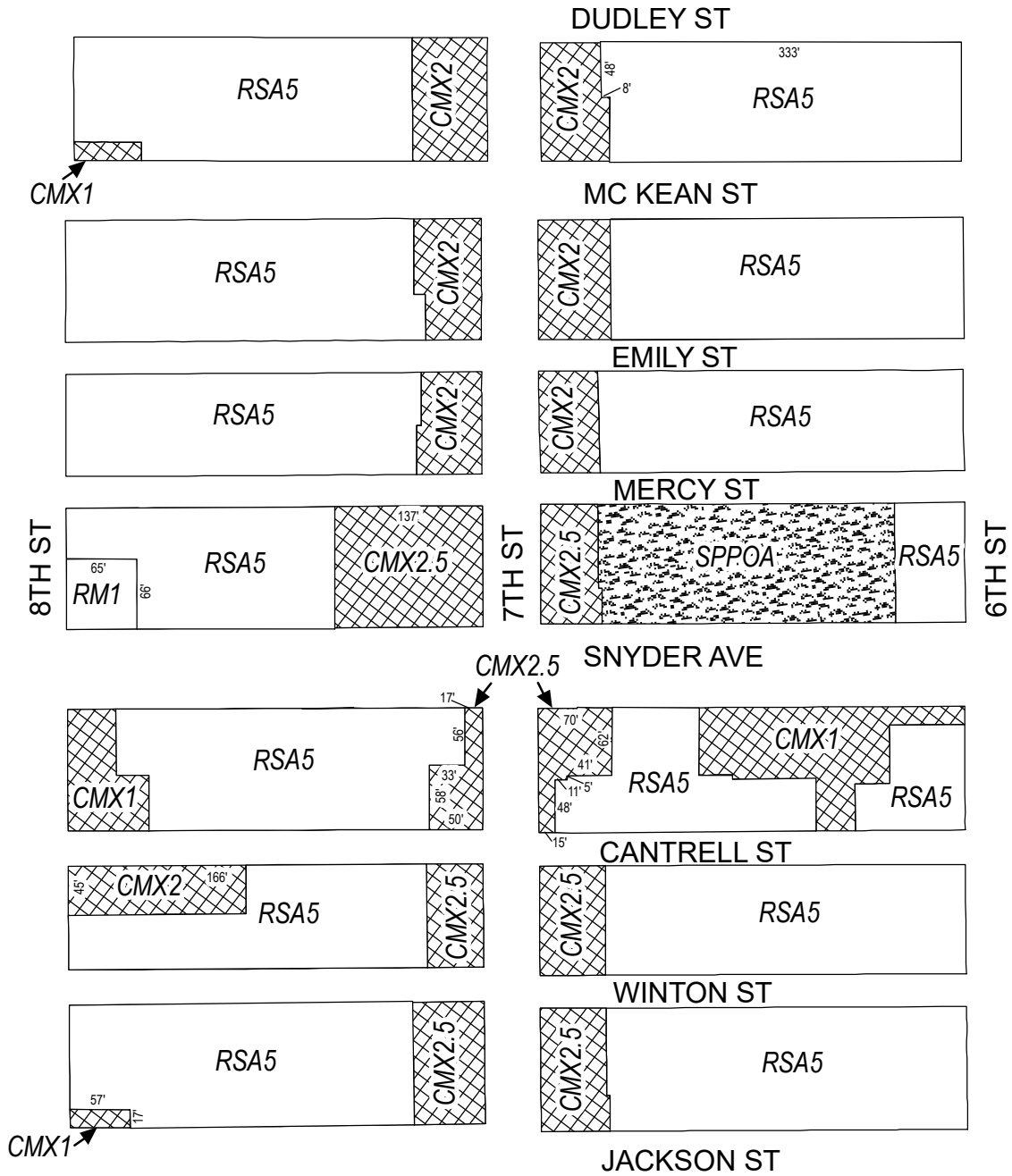

# Map B2 Proposed Zoning



## Zoning Districts

-  CMX-1/CMX-2/CMX-2.5, Commercial Mixed-Use
-  RM-1, Residential Multi-Family; RSA-5, Residential Single-Family Attached
-  SP-PO-A, Special Purpose Open Space



# Map B3 Proposed Zoning

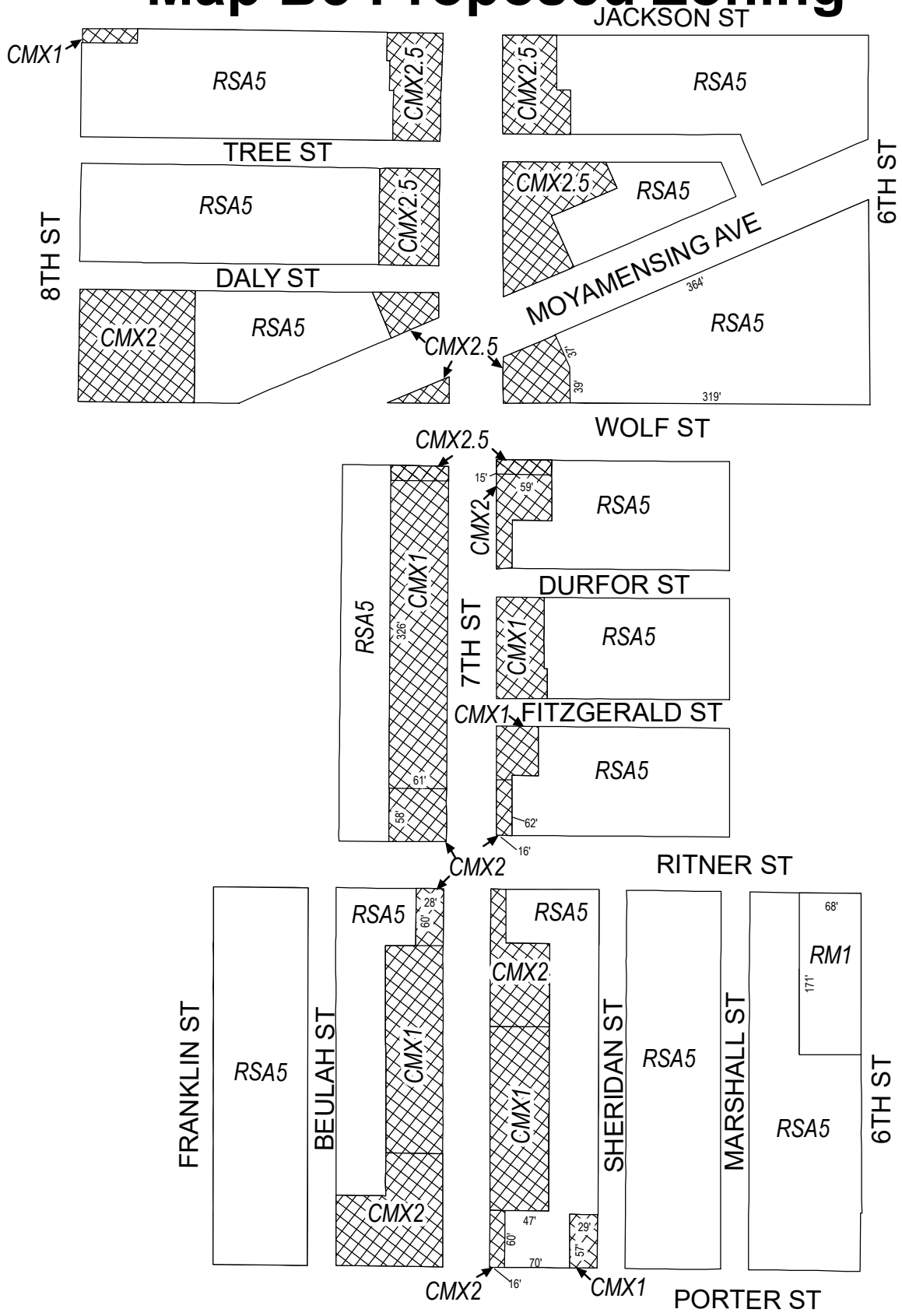

## Zoning Districts

 CMX-1/CMX-2/CMX-2.5, Commercial Mixed-Use

 RM-1, Residential Multi-Family; RSA-5, Residential Single-Family Attached





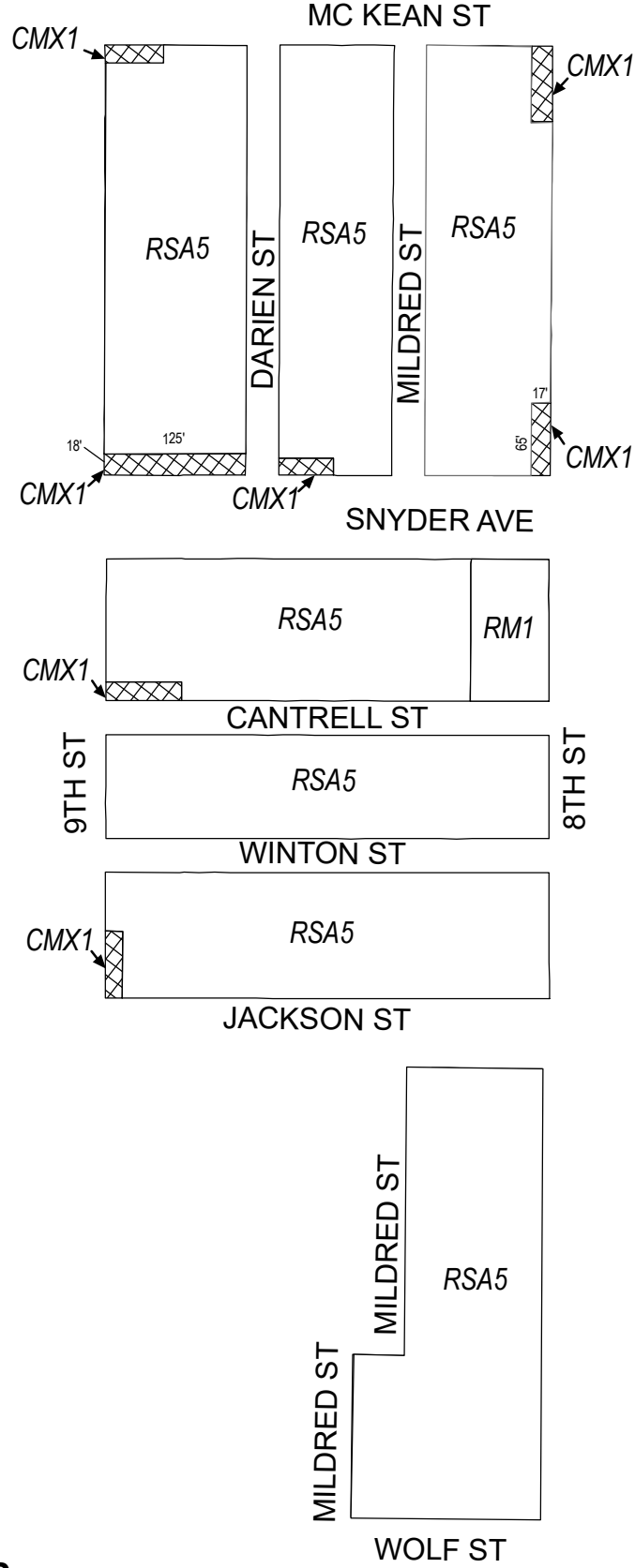

# Map B4 Proposed Zoning



## Zoning Districts

-  CMX-1, Commercial Mixed-Use
-  RM-1, Residential Multi-Family; RSA-5, Residential Single-Family Attached



# Map B5 Proposed Zoning

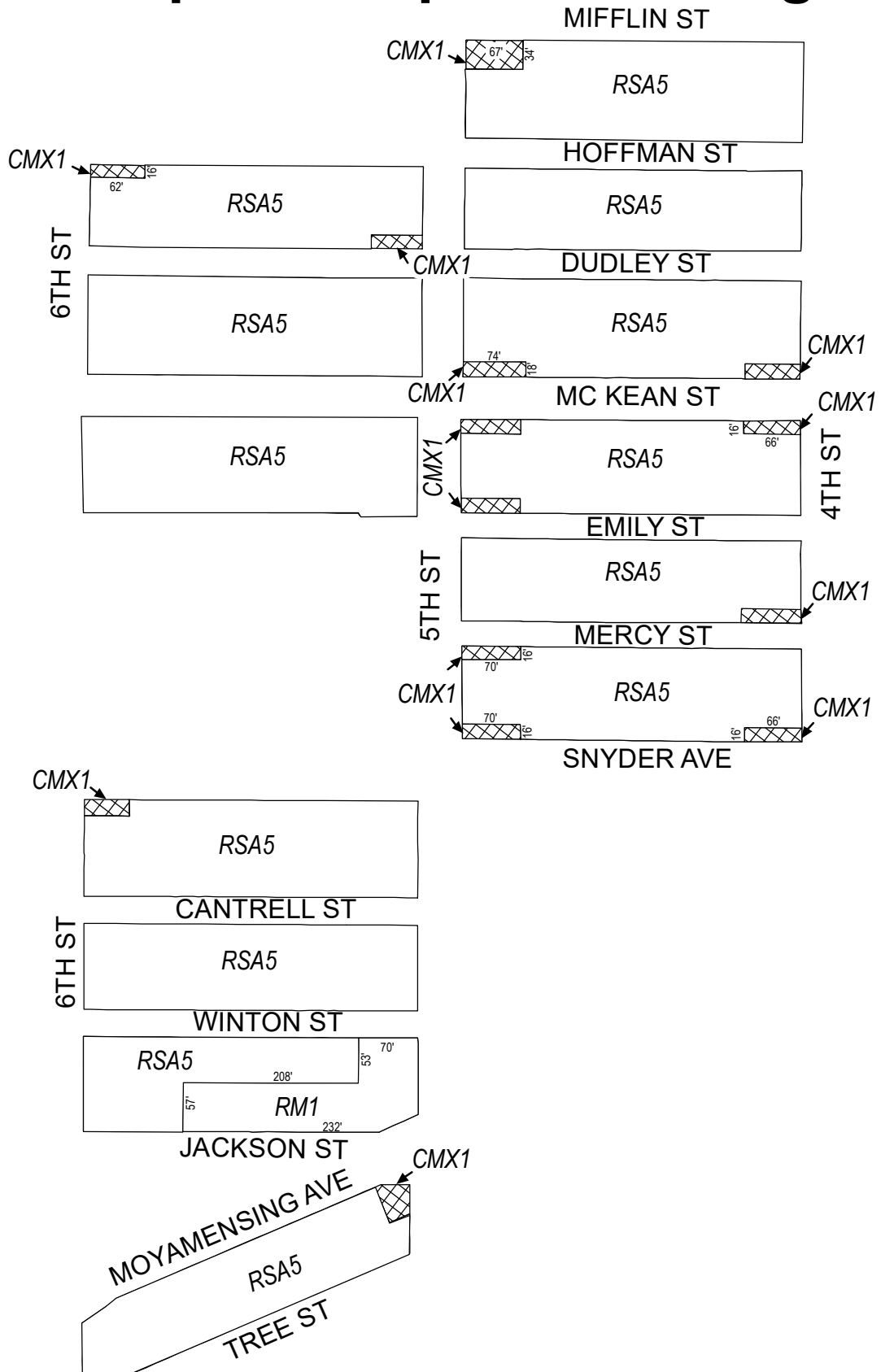

## Zoning Districts

 CMX-1, Commercial Mixed-Use

 RM-1, Residential Multi-Family; RSA-5, Residential Single-Family Attached

