

City – PAID Street Light Use Agreement

City of Philadelphia
Wireless Philadelphia Closing
February 21, 2006

STREET LIGHT USE AGREEMENT

By and between

THE CITY OF PHILADELPHIA

And

PHILADELPHIA AUTHORITY FOR INDUSTRIAL DEVELOPMENT

This Street Light Use Agreement (the "Agreement") is entered into as of February 21, 2006 and is effective on the "Effective Date" as defined in Section 1, by and between the City of Philadelphia, acting by and through its Office of the Managing Director (the "City") and the Philadelphia Authority for Industrial Development ("PAID").

BACKGROUND

WHEREAS, extraordinary and unparalleled advances in technology relating to internet communication have had, and have the potential to expand, a profound effect on business and commerce, education and the lives of ordinary citizens;

WHEREAS, the ability to connect via the worldwide web offers accelerated access to information and the exchange of ideas, creating enormous opportunities for economic development, delivery of more efficient municipal services and disadvantaged children and adults to realize their potential;

WHEREAS, the City has determined that the safety, general welfare, economic development and prosperity of the people of Philadelphia are dependent upon accelerated technological improvements to the communications systems available in the City and accessibility of those improvements to the broadest segments of the population;

WHEREAS, the City has determined to act as a catalyst to encourage, promote, and attract expanded communications systems within the City, and most particularly to develop a city-wide wireless network;

WHEREAS, the City has determined that this network alone will be insufficient to afford full internet accessibility to low income residents, but that programs focusing on hardware and software availability as well as education and training are also necessary;

WHEREAS, the City desires to foster and stimulate collaboration between and among private entrepreneurs, non-profit agencies and government to afford the broadest

range of benefits of internet advances to the general public through a business model which will appropriately allocate the risks and rewards of city-wide internet deployment;

WHEREAS, the Philadelphia Authority for Industrial Development is a public instrumentality of the Commonwealth of Pennsylvania organized under the Pennsylvania Economic Development Financing Law, Act No. 102, approved April 23, 1967, as amended, for the purposes, among others, of promoting the installation and use of the most efficient means of communications, promoting public and private infrastructure, and promoting industrial, commercial and other economic development in the City of Philadelphia;

WHEREAS, the Philadelphia Industrial Development Corporation (“PIDC”) is a nonprofit corporation organized under the laws of Pennsylvania for the purpose, among others, of assisting PAID in carrying out its economic development and other purposes;

WHEREAS, the City has determined that fostering the growth of a city-wide wireless network will be best accomplished by implementing a business model which will utilize municipally-owned assets for deployment and operation of such a network are made available to a locally-controlled not-for-profit corporation, Wireless Philadelphia;

WHEREAS, Wireless Philadelphia has determined that the implementation of such network will be best accomplished by partnering with a private entrepreneur;

WHEREAS, to support this business model, the City desires to grant to PAID certain rights for the placement of wireless communications equipment on certain municipally-owned street light fixtures, referred to herein as the Street Lights, and to authorize PAID to authorize EarthLink, Inc., a Delaware for-profit corporation (“EL” or “EarthLink”) with substantial business expertise as an internet service provider and a developer of municipal wireless networks, to use the Street Lights for the placement of such equipment;

WHEREAS, in consideration for such right to use the Street Lights, the City will receive street light use fees, funding for certain costs, free and discounted service rights; Wireless Philadelphia will receive portions of the revenues generated by EarthLink for the operation of its programs to lower the cost of internet access and to provide citizens of Philadelphia with the knowledge, training, and equipment to benefit from the area-wide network and to otherwise manage its operations;

WHEREAS, PAID and EarthLink have entered into that certain Street Light Use Agreement dated February 21, 2006 (attached hereto as Exhibit A and incorporated herein by reference), subject to the City Council’s adoption of an ordinance approving the Agreement and the ordinance becoming law, whereby PAID has authorized the foregoing use of the Street Lights by EarthLink, subject to the terms and conditions provided in the Agreement (the “EL/PAID Agreement”);

WHEREAS, PAID and the City desire to enter into this Agreement to provide for the City’s authorization to PAID to enter into the EL/PAID Agreement and to authorize

EarthLink's use of the Street Lights as provided therein, and subject to City Council's approval of this Agreement and the EL/PAID Agreement.

NOW, THEREFORE, in consideration of the above recitals and the following mutual covenants, agreements, and obligations of the parties, which constitute good and valuable consideration, the sufficiency of which is acknowledged, and with the intention to be legally bound hereby, the City and PAID agree as follows:

- 1 **Definitions.** Capitalized terms in this Agreement shall have the meanings defined herein, and if not defined herein, then the meaning defined in the EL/PAID Agreement. "Effective Date" means the later of (i) the date first written above, (ii) the date on which this Agreement and the EL/PAID Agreement are fully executed, or (iii) the date on which an ordinance of City Council approving the Agreement becomes law.
- 2 **Authorization: City Obligations.**
 - 2.1 **Authorization.** Subject to the terms and conditions of this Agreement and for the term provided herein, the City hereby authorizes PAID to use the Street Lights for the sole purpose of PAID's authorizing EL to use the Street Lights for the Authorized Uses provided in Section 2.1 of the EL/PAID Agreement; provided, that such use of the Street Lights by EL shall be subject to and in accordance with the terms and conditions of the EL/PAID Agreement. The City hereby approves the EL/PAID Agreement and hereby consents to and authorizes PAID's entering into the EL/PAID Agreement to authorize EL to use Street Lights for the Authorized Uses provided in Section 2.1 of the EL/PAID Agreement. Such approval, consent, and authorization by the City shall be effective throughout the Initial Term and any Renewal Terms of the EL/PAID Agreement or, if longer, the term of this Agreement.
 - 2.2 **City Obligations.** The City hereby covenants and agrees that it shall perform all obligations that are set forth in the EL/PAID Agreement as obligations of the City, its Streets Commissioner, its Streets Department, or any other office, officer or department of the City and not as obligations of EL (including, without limitation, the City's obligations to direct or otherwise authorize PAID to take action where such direction or authorization is set forth in the EL/PAID Agreement as a condition of PAID's taking action), subject to the applicable notice and cure periods and other rights provided to PAID and/or the City in the EL/PAID Agreement with respect to such obligations. Such covenant and agreement shall be effective throughout the Initial Term and any Renewal Terms of the EL/PAID Agreement or, if longer, the term of this Agreement. Without in any way limiting the generality of this Section 2.2, the City expressly acknowledges its undertakings under the following sections of the EL/PAID Agreement: 2.4.3; 3.2.1; 3.2.3; 3.2.4; 4.2.1; 5.1.1.2; 5.3; 5.4; 5.5.1; 5.6; 5.8; 5.11; 6.2; 6.4; 7.1.3.1; 7.1.3.4; 7.5; 9.3.2; 10.1, and 12.2.3.

- 2.3 Title and Quiet Enjoyment. Subject to the rights of the City and PAID in this Agreement, and provided that PAID is in compliance with the Agreement, PAID shall have quiet enjoyment of the designated Street Lights for the term of the Agreement.
- 3 Obligations of PAID.
- 3.1 PAID shall enter into the EL/PAID Agreement and shall perform and carry out all of PAID's limited obligations set forth therein, in good faith, throughout the term of the EL/PAID agreement. Notwithstanding the foregoing or anything contained in this Agreement or anything contained in the Wireless Philadelphia Transactional Documents to the contrary, PAID shall have no obligation to oversee, supervise, review or monitor the performance by EL or Wireless Philadelphia of any of their obligations under the Wireless Philadelphia Transactional Documents; the City shall be responsible for such functions. The City further acknowledges and agrees that in no circumstance whatsoever shall PAID have any liability or responsibility to maintain or repair or to pay any sums toward the operating or maintenance costs of the Street Lights, the Communications Equipment to be placed thereon pursuant to the EL/PAID Agreement, or the Wireless Network; all such liability and responsibility shall either remain with the City or rest with EL.
- 3.2 In consideration of the authorization provided under Section 2.1 above, PAID shall require EarthLink (in the EL/PAID Agreement) to pay for the account of the City, as non-refundable use fees for the Street Lights, the payments required under Section 7.1. 1, *Prepayment of Street Light Use Fees*, and Section 7.1.2, *Monthly Street Light Use Fee* of the EL/PAID Agreement, in such manner and by such time as the City directs, with PAID's reasonable agreement.
- 3.3 PAID shall use good faith efforts to notify the City promptly of (i) any breach of the terms and conditions of the EL/PAID Agreement by EL, and (ii) any claim by EL that PAID has breached any of the terms and conditions of the EL/PAID Agreement and/or that the City has breached any obligation of the City set forth in the EL/PAID Agreement. PAID shall cooperate with the City as reasonably requested by the City in the resolution of any dispute under Section 10, *Dispute Escalation*, of the EL/PAID Agreement. PAID shall cooperate as reasonably requested by the City in the defense of any claim or suit asserted against the City in a court of competent jurisdiction or other forum and arising from the EL/PAID Agreement, this Agreement, the Network Agreement, or the construction and operation of the Wireless Network; provided, however, that nothing contained herein shall in any way limit or preclude PAID from enforcing or from allowing EL to enforce any and all of the City's undertakings under the EL/PAID Agreement or hereunder, subject to and in accordance with Section 19, *Third Party Beneficiaries*, of this Agreement.

4 Term.

This Agreement shall commence on the Effective Date and shall continue in effect thereafter until thirty (30) days after the date the EL/PAID Agreement is terminated in accordance with its terms; the City and PAID have each completed all of their undertakings and obligations under the EL/PAID Agreement, this Agreement, and any other of the "Wireless Philadelphia Transactional Documents," as defined below; and the City and PAID have terminated this Agreement in writing.

5 Payment of PAID's Expenses.

Notwithstanding anything to the contrary contained in this Agreement, the EL/PAID Agreement or any other transactional documents, to which PAID is a party or otherwise required to undertake any activities, related to the creation of the City wide wireless broadband internet access system (collectively, "Wireless Philadelphia Transactional Documents"), the City agrees to pay promptly when due to PAID or on PAID's behalf, all fees, costs and expenses reasonably incurred by PAID, including but not limited to the consulting and administrative fees and expenses of PIDC and reasonable attorneys' fees and expenses, whenever incurred, in connection with the negotiation, execution, delivery and performance under, any of the Wireless Philadelphia Transactional Documents.

6 City Covenants.

- 6.1 The City covenants to perform its obligations under the Wireless Philadelphia Transactional Documents, including but not limited to the obligations imposed on the City pursuant to the EL/PAID Agreement even though the City is not a party thereto, fully, faithfully and in a timely fashion.
- 6.2 Except as otherwise specifically agreed to by the City and PAID, the City covenants to do all of the actions which PAID covenants under the terms of the Wireless Philadelphia Transactional Documents to do, or require the City to do, in each case, fully, faithfully and in a timely fashion.
- 6.3 As requested by PAID, the City will designate certain employees who will consult with PAID regarding PAID's performance under the Wireless Philadelphia Transactional Documents and, as requested by PAID, perform any of PAID's responsibilities and prepare any documents required of PAID under the Wireless Philadelphia Transactional Documents. In addition, the City expressly undertakes to perform the obligations of PAID and otherwise to comply with PAID's affirmative and negative covenants in any of the Wireless Philadelphia Transactional Documents. The Managing Director of the City of Philadelphia or his designee shall perform these duties.

7 Representation of Authority.

The City represents that the City has reasonably concluded that: (i) subject to the condition that City Council approves this Agreement by ordinance and the ordinance becomes law, the City has the requisite power and authority to execute and deliver and carry out and perform this Agreement, and to grant to PAID the right to enter into and to carry out and perform the EL/PAID Agreement; (ii) the City has no actual knowledge of, nor has it received any legal notice of, any fact, act or omission which is inconsistent with this conclusion; and (iii) subject to the condition that City Council approves this Agreement by ordinance and the ordinance becomes law, its execution and delivery by the City is duly and validly authorized by all necessary action, and when executed and delivered, this Agreement is the legal, valid, and binding obligation of the City, enforceable in accordance with its terms. The City hereby authorizes PAID to grant to EL the right to rely on this representation.

8 Approval by City Council.

Notwithstanding the execution of this Agreement by PAID and the City, the Agreement shall have no force or effect unless or until approved by City Council by ordinance and the ordinance becomes law.

9 Duties and Covenants Pursuant to 17-1400.

9.1 PAID shall abide by the provisions of Philadelphia Code Chapter 17-1400 in awarding any contract(s) pursuant to this Agreement as though such contracts were directly subject to the provisions of Chapter 17-1200, except that the exception set forth at Subsection 17-1406(8) shall apply to Provider as if Provider were listed in that subsection.

9.2 Unless approved by the City to the contrary, any approvals required by the Philadelphia Code Chapter 17-1400 to be performed by the City Solicitor shall be performed by PAID by its General Counsel; any approvals required to be performed by the Director of Finance shall be performed by PAID by its Chief Financial Officer; and any approvals required to be performed by the Mayor shall be performed by PAID by its Chairman.

10 Standard City Provisions. PAID agrees that in addition to Section 9 (*Duties and Covenants Pursuant to 17-400*), PAID will in its performance under this Agreement comply with all applicable laws, including without limitation, the City provisions found in Chapter 17-400 of The Philadelphia Code and the McBride Principals. Failure to do so shall constitute a substantial breach of this Agreement entitling the City to all rights and remedies provided in this Agreement or otherwise available in law or equity. In addition, it is understood that false certification or representation is subject to prosecution under Title 18 Pa. C.S.A. Section 4904.

11 Rights Against EarthLink and Other Third Parties.

Provided the City is current in the performance of all of its obligations to PAID hereunder, the City shall have the right, with the consent of PAID, to pursue all remedies which PAID may have against EarthLink or any third party under any of the Wireless Philadelphia Transactional Documents.

12 Litigation.

In the event of any litigation arising out of or relating to the Wireless Philadelphia Transactional Documents, the performance of PAID's obligations thereunder, or by reason of PAID's being a party thereto, including but not limited to claims by EarthLink, its contractors or any third party, PAID shall, within four (4) business days of receipt, deliver all process served upon it directly to the City Solicitor. All such process will be directed to the attention of the City Solicitor. The City Solicitor will either enter his appearance on behalf of PAID in a timely fashion or retain counsel which will enter its appearance on behalf of PAID in a timely fashion. The City shall defend PAID in all such actions at the City's sole cost and expense and the City shall have the right to control the defense of such proceeding but shall keep PAID advised as to all material developments in such proceeding. All information with respect to litigation will be sent to PAID to the attention of Philip M. Brandt, Esquire at PIDC. The City Solicitor shall be permitted to arrange for defense of PAID by any applicable insurer pursuant to any insurance policy maintained by any third party (other than PIDC) under which PAID is an endorsed named insured.

13 Indemnification.

- 13.1 To the extent (i) that a party to any of the Wireless Philadelphia Transactional Documents fails to provide reasonable and timely indemnification against Claims or Losses (as defined below), (ii) permitted by Applicable Laws and subject to Section 14, *No Waiver of Immunity*, hereof, and (iii) that Claims or Losses are not covered under an insurance policy maintained by a third party (other than PIDC) for the benefit of PAID pursuant to the terms of any of the Wireless Philadelphia Transactional Documents, the City agrees, to the extent permitted by law, to indemnify, defend and hold harmless PAID and PIDC, and each of their directors, members, officials, officers, employees, agents and representatives (each an "Indemnified Party" and collectively, the "Indemnified Parties"), from and against any and all suits, claims or causes of action (collectively "Claims"), and all liabilities, losses, obligations, damages, penalties, costs, charges, expenses, judgments and amounts paid in settlement (including without limitation, reasonable attorneys' fees) of every kind (collectively "Losses"), which may be imposed upon, incurred by or asserted against any Indemnified Party arising out of or relating to or arising in connection with PAID's entering into this Agreement and/or any of the other Wireless Philadelphia Transactional Documents, the performance of any of PAID's obligations hereunder or thereunder, any acts or omissions with respect to PAID's interest under this Agreement and/or any of the Wireless Philadelphia Transactional Documents, or any other acts or omissions relating to PAID's involvement hereunder or thereunder; except in each case to the extent that the

Claims and Losses are attributable to the negligence or willful misconduct of any such Indemnified Party. In consideration of this undertaking by the City, PAID hereby agrees to cooperate with the City to enforce PAID's rights under any insurance policies maintained by any third party (other than PIDC) under which PAID is an additional or named insured, and to enforce any indemnification rights to which PAID may be entitled under any of the Wireless Philadelphia Transactional Documents (including but not limited to any rights against EarthLink or any other third party), and the City and PAID agree to pursue all such third party insurance policies and indemnitors diligently with respect to all Claims or Losses which may be properly asserted in good faith against them. The City shall be subrogated to the rights of PAID under such insurance policies and indemnification rights; provided, however, it is expressly agreed that the City shall not have, and expressly waives, any right of subrogation under any insurance policies maintained by PAID or PIDC. To the extent that either (i) any party to any of the Wireless Philadelphia Transactional Documents, other than the City, provides reasonable and timely indemnification against any Claims or Losses, or (ii) Claims are covered by an insurer under an insurance policy maintained by a third party (other than PIDC) for the benefit of PAID without reservation of rights and Losses under such Claims are paid by such insurer on a basis such that PAID does not incur any liability, then in each case, the City's obligations under this provision with respect to such specific Claims and Losses will be discharged. The City acknowledges that PAID shall not be obligated to exhaust any remedies against any third party as a condition to its right to receive indemnification hereunder. The indemnification provided herein is intended to be in addition to any indemnification by the City in favor of PAID provided elsewhere in the Wireless Philadelphia Transactional Documents.

- 13.2 To the extent (i) that any party to any of the Wireless Philadelphia Transactional Documents other than the City or PAID fails to provide reasonable and timely indemnification against Claims or Losses, (ii) permitted by Applicable Laws and subject to Section 14, "No Waiver of Immunity", and (iii) that Claims or Losses are not covered under an insurance policy maintained by or for the benefit of the City (other than PIDC's insurance), PAID hereby agrees to indemnify, defend and hold harmless the City and its officers, officials, employees and agents from and against any and all Losses which may be imposed upon, incurred by or asserted against the City and its officers, officials, employees and agents arising out of or relating to (i) the performance or breach of the obligations or representations of PAID under this Agreement and/or any of the Wireless Philadelphia Transactional Documents, or (ii) any other acts or omissions of PAID or any of its directors, members, officers, officials, employees, agents and attorneys providing services related thereto or thereunder, in each case insofar as such Claims or Losses arise directly or indirectly from the willful misconduct, fraud or negligence of PAID or any Indemnified Party (as defined above). The liability of PAID, PIDC and any other indemnified party hereunder is limited solely to PAID's interest under this Agreement and/or any of the Wireless Philadelphia Transactional Documents, and the lien of any judgment shall be restricted thereto.

- 13.3 PAID's taking of any action, or the failure to take any action, which it is permitted to take under the terms of this Agreement and/or any of the Wireless Philadelphia Transactional Documents shall under no circumstances be deemed to constitute willful misconduct, fraud or negligence, and furthermore, the taking of any action by PAID, which action is directed in writing by the City, pursuant to the Wireless Philadelphia Transactional Documents shall not under any circumstances be deemed to constitute willful misconduct, fraud or negligence.
- 13.4 The parties agree that neither shall be obligated under this Section 13 unless the indemnifying party has been given prompt and timely notice of matters contemplated herein; provided, however, the failure to so notify the indemnifying party will not relieve the indemnifying party from any obligation under this Section 13 except to the extent such failure has materially injured the ability of the indemnifying party to defend such matter successfully or to minimize the economic exposure resulting therefrom.

14 No Waiver of Immunity.

Nothing herein shall be construed to waive or amend any defense or immunity which the City or PAID, or their officials, members, officers, agents, employees or representatives may have under Title 42, Chapter 85 of the Pennsylvania Consolidated Statutes Annotated, as amended, or other Applicable Law. The parties expressly acknowledge that this Section 14 is intended to preclude any third party (not otherwise expressly given third party rights) from having any rights whatsoever hereunder against either party and is not intended in any way to constitute a defense against, or otherwise limit, the obligations of the City hereunder to pay the costs, expenses, Claims and Losses of PAID as provided herein.

- 15 Survival. The rights and obligations of the parties under Sections 5, 6, 11-14, 15, and 19 (but only as to a claim of EL that this Agreement has been wrongfully terminated) shall survive termination of this Agreement or any of the other Wireless Philadelphia Transactional Documents.

16 No Personal Liability.

- 16.1 Notwithstanding any provision or obligation to the contrary set forth in this Agreement or in any Wireless Philadelphia Transactional Document, no provision herein or therein shall be construed so as to give rise to any pecuniary liability of PAID or its members, directors, officers, employees, agents, subcontractors, or representatives or to give rise to a charge upon or claim against the general credit or assets of PAID or of such members, directors, officers, employees, agents, subcontractors, or representatives, in each case except to the extent of PAID's economic interest in this Agreement as set forth in the next sentence. Any pecuniary liability hereunder of PAID under any theory of law, including contract or tort, shall be limited exclusively to its interests in the Wireless Philadelphia

Transactional Documents and the lien of any judgment shall be restricted thereto.

- 16.2 No member, director, officer, official, employee or agent of any party hereto shall be personally liable for any costs or obligations of such party. All persons, corporations, or other entities extending credit to, contracting with or having any claim against any party, may look only to the funds and property of such party for payment of any such suit, contract or claim to the extent such party is liable therefor, or for the payment of any costs that may become due or payable to them from any party, respectively, and not from any member, director, officer, official, agent or employee of any party.
- 16.3 In no event shall PAID be liable or responsible for any injury or damage to any property or to any person arising out of or in connection with the use of the Street Lights authorized hereunder or under any of the Wireless Philadelphia Transactional Documents or the operation of the Wireless Network, nor for any injury or damage to the Street Lights or poles or any property of any third person or the City arising out of or in connection with the same, or due to the use, misuse or abuse of the same, or for any kind of injury or damage which may arise from any other cause whatsoever relating to the same. This Section 16.3 is not intended to modify the responsibility or liability of the City or EL with respect to their undertakings pursuant to the Wireless Philadelphia Transactional Documents. PAID and the City agree that nothing in this Section 16.3 shall diminish the rights of EL to enforce the obligations of the City as set forth in Section 19 of this Agreement.
- 17 Assignment. Neither party shall assign this Agreement, or any portion of it, without the prior written consent of the other party, and any such assignment made without such consent shall be void and unenforceable; provided, however, as follows: (i) the City may, in its sole discretion and upon written notice to PAID, assign the Agreement to another City-related authority or agency created pursuant to the Pennsylvania Municipal Authorities Act of 1945, as amended, or the Pennsylvania Economic Development Financing Law, Act No. 102, approved April 23, 1967, as amended, that has substantially the same powers, purposes, and authority as has PAID, including the power and authority to enter into the EL/PAID Agreement; (ii) such assignee must agree, as a condition of the assignment, to be bound to the extent PAID is bound under this Agreement and the EL/PAID Agreement; and (iii) notwithstanding anything contained herein to the contrary, no assignment by the City shall relieve the City from any covenant or obligation hereunder, and the City shall continue to remain primarily, jointly and severally, liable and obligated for all covenants and obligations hereunder.
- 18 Notices. All notices shall be in writing and delivered in person with receipt or confirmation of receipt obtained, or sent by United States Certified Mail, Return Receipt Requested, or by overnight delivery service with signature acknowledging delivery required, at the following addresses or such other address as may be designated in writing:

If to PAID:

Philadelphia Authority for Industrial Development
2600 Centre Square West
1500 Market Street
Philadelphia, PA 19102-2126
Attn: Philip Brandt, Esquire

If to City:

Managing Director
City of Philadelphia
Municipal Services Building, Suite 1430
1401 JFK Boulevard
Philadelphia PA 19102

With copies to:

City Solicitor
1515 Arch Street, 17th Floor
Philadelphia, PA 19102

19 Third Party Beneficiaries.

- 19.1 PAID and the City expressly agree that EL is an intended third party beneficiary of the obligations of the City under the following Sections of this Agreement (collectively, the "EL Enforceable Provisions"): Section 2 (*Authorization; City Obligations*); Section 4 (*Term*); Sections 6.1 and 6.2 (*City Covenants*); Section 7 (*Representation of Authority*); Section 15 (*Survival*), but only as to the EL Enforceable Provisions that are set forth in Section 15; Section 17 (*Assignment*), but only as to clauses (ii) and (iii); Section 18 (*Notices*); this Section 19; and Sections 20.1-20.11 (*Miscellaneous*), but only to the extent directly related to and a condition to the enforcement of the provisions as to which EL has been expressly given third party beneficiary rights under this Section 19.1.

EL shall be entitled to enforce the terms and conditions of the EL Enforceable Provisions (subject to and in accordance therewith, and as to PAID and the City, subject to their respective limitations of liability set forth in the EL/PAID Agreement) in its own name and on its own behalf against either or both of the City and PAID, provided that in the exercise of such rights, (i) EL is bound by the terms and conditions of this Agreement as PAID and the City are bound thereby, provided, however, that the liability disclaimers provided with respect to PAID and the City in Section 16, *No Personal Liability*, shall not preclude EL's enforcement

of the EL Enforceable Provisions against the City, and (ii) such rights may only be exercised in accordance with Section 19.2.

The foregoing rights of EL as third party beneficiary shall, subject to the conditions set forth in Section 19.2, vest immediately upon the Effective Date of this Agreement, and may not be modified or diminished except with the written consent of EL. Except as expressly provided otherwise in this Section 19 or elsewhere in this Agreement, nothing in this Agreement, express or implied, is intended or shall be construed to confer upon or give to any person, firm, corporation, or legal entity, other than PAID, the City and EL any rights, remedies, or other benefits under or by reason of the Agreement. PAID and the City agree that EL shall be entitled to exercise specific performance and all equitable remedies, except as provided in Section 19.3 below.

19.2 The rights of EL as third party beneficiary set forth in Section 19 shall be effective only if all of the conditions provided in Sections 19.2.1 and 19.2.2 are satisfied:

19.2.1 In the event that EL believes the City has by its act or omission failed to perform any of its duties or obligations as specified in the EL Enforceable Provisions or caused PAID to be in breach of the EL/PAID Agreement, then EL must certify the same to PAID and the City in writing and must assert in the certification EL's written demand that PAID enforce such duties or obligations of this Agreement against the City.

19.2.2 Upon receipt of such certification, PAID shall within twenty-five (25) days of such certification (or such earlier time as is reasonably specified in the certification if the certification reasonably states that irreparable damage is imminent) either (i) at EL's cost and using attorneys approved by EL, institute legal proceedings to enforce the City's duties or obligations as specified in the EL/PAID Agreement and in the EL Enforceable Provisions; or (ii) notify EL that it will not institute such legal proceedings. If PAID notifies EL that it will not institute such legal proceedings, or if, without such notification, PAID does not start such proceedings within the times specified above and/or does not then diligently and expeditiously pursue such proceedings, then the third party beneficiary rights of EL set forth in this Section 19 shall immediately be effective without further action on the part of PAID or EL and EL may thereafter institute such legal proceedings against the City in its own name.

19.3 Notwithstanding anything to the contrary in this Section 19 or elsewhere in this Agreement, or in the EL/PAID Agreement, EL shall not have the right under this Section 19 or otherwise under this Agreement to specific performance or any equitable remedy, including, without limitation, injunctive relief, against the City or PAID for the City's or PAID's failure to comply with Section 2.2 (*Authorization Not Exclusive*) of the EL/PAID Agreement or any provision of similar effect in this Agreement.

- 19.4 PAID and the City shall not breach, terminate or amend this Agreement or the EL/PAID Agreement in any way that would materially diminish or adversely and materially affect the grants to EarthLink, the rights of EarthLink, or the obligations of PAID to EarthLink, that are contained in the EL/PAID Agreement.
- 19.5 The City acknowledges that these provisions may operate for the benefit of EarthLink.
- 19.6 The following provision shall be included in the EL/PAID Street Light Use Agreement:

17.24 EL Third Party Beneficiary of City/PAID Agreement.

PAID agrees that the following provision shall be included in the City/PAID Street Light Use Agreement:

19 Third Party Beneficiaries.

- 19.1 PAID and the City expressly agree that EL is an intended third party beneficiary of the obligations of the City under the following Sections of this Agreement (collectively, the "EL Enforceable Provisions"): Section 2 (*Authorization; City Obligations*); Section 4 (*Term*); Sections 6.1 and 6.2 (*City Covenants*); Section 7 (*Representation of Authority*); Section 15 (*Survival*), but only as to the EL Enforceable Provisions that are set forth in Section 15; Section 17 (*Assignment*), but only as to clauses (ii) and (iii); Section 18 (*Notices*); this Section 19; and Sections 20.1-20.11 (*Miscellaneous*), but only to the extent directly related to and a condition to the enforcement of the provisions as to which EL has been expressly given third party beneficiary rights under this Section 19.1.

EL shall be entitled to enforce the terms and conditions of the EL Enforceable Provisions (subject to and in accordance therewith, and as to PAID and the City, subject to their respective limitations of liability set forth in the EL/PAID Agreement) in its own name and on its own behalf against either or both of the City and PAID, provided that in the exercise of such rights, (i) EL is bound by the terms and conditions of this Agreement as PAID and the City are bound thereby, provided, however, that the liability disclaimers provided with respect to PAID and the City in Section 16, *No Personal Liability*, shall not preclude EL's enforcement of the EL Enforceable Provisions against the City, and (ii) such rights may only be exercised in accordance with Section 19.2.

The foregoing rights of EL as third party beneficiary shall, subject to the conditions set forth in Section 19.2, vest immediately upon the Effective Date of this Agreement, and may not be modified or diminished except with the written consent of EL. Except as expressly provided otherwise in

with the written consent of EL. Except as expressly provided otherwise in this Section 19 or elsewhere in this Agreement, nothing in this Agreement, express or implied, is intended or shall be construed to confer upon or give to any person, firm, corporation, or legal entity, other than PAID, the City and EL any rights, remedies, or other benefits under or by reason of the Agreement. PAID and the City agree that EL shall be entitled to exercise specific performance and all equitable remedies, except as provided in Section 19.3 below.

19.2 The rights of EL as third party beneficiary set forth in Section 19 shall be effective only if all of the conditions provided in Sections 19.2.1 and 19.2.2 are satisfied:

19.2.1 In the event that EL believes the City has by its act or omission failed to perform any of its duties or obligations as specified in the EL Enforceable Provisions or caused PAID to be in breach of the EL/PAID Agreement, then EL must certify the same to PAID and the City in writing and must assert in the certification EL's written demand that PAID enforce such duties or obligations of this Agreement against the City.

19.2.2 Upon receipt of such certification, PAID shall within twenty-five (25) days of such certification (or such earlier time as is reasonably specified in the certification if the certification reasonably states that irreparable damage is imminent) either (i) at EL's cost and using attorneys approved by EL, institute legal proceedings to enforce the City's duties or obligations as specified in the EL/PAID Agreement and in the EL Enforceable Provisions; or (ii) notify EL that it will not institute such legal proceedings. If PAID notifies EL that it will not institute such legal proceedings, or if, without such notification, PAID does not start such proceedings within the times specified above and/or does not then diligently and expeditiously pursue such proceedings, then the third party beneficiary rights of EL set forth in this Section 19 shall immediately be effective without further action on the part of PAID or EL and EL may thereafter institute such legal proceedings against the City in its own name.

19.3 Notwithstanding anything to the contrary in this Section 19 or elsewhere in this Agreement, or in the EL/PAID Agreement, EL shall not have the right under this Section 19 or otherwise under this Agreement to specific performance or any equitable remedy, including, without limitation, injunctive relief, against the City or PAID for the City's or PAID's failure to comply with Section 2.2 (*Authorization Not Exclusive*) of the EL/PAID Agreement or any provision of similar effect in this Agreement.

19.4 PAID and the City shall not breach, terminate or amend this Agreement or the EL/PAID Agreement in any way that would materially diminish or

adversely and materially affect the grants to EarthLink, the rights of EarthLink, or the obligations of PAID to EarthLink, that are contained in the EL/PAID Agreement.

19.5 The City acknowledges that these provisions may operate for the benefit of EarthLink.

20 Miscellaneous Provisions.

20.1 Governing Law; Forum and Jurisdiction.

This Agreement and all disputes arising under the Agreement shall be governed, construed and decided in accordance with the laws of the Commonwealth of Pennsylvania. The parties agree that any lawsuit, action, claim, or legal proceeding involving, directly or indirectly, any matter arising out of or related to this Agreement, or the relationship created or evidenced thereby, shall be brought exclusively in the United States District Court for the Eastern District of Pennsylvania (“EDPA”) or in a Pennsylvania state court sitting in Philadelphia County. It is the express intent of the Parties that jurisdiction over any lawsuit, action, claim, or legal proceeding shall lie exclusively in one of these forums. The parties further agree not to raise any objection, as to forum or venue, to any lawsuit, action, claim, or legal proceeding which is brought in one of these forums, and the parties expressly consent to the jurisdiction and venue of these forums.

20.2 Successors and Assigns. Without limiting the provisions of Section 17, *Assignment*, of this Agreement, the terms, covenants and conditions contained in this Agreement shall extend to and be binding upon the parties hereto and their respective heirs, personal representatives, successors and assigns.

20.3 Severability. If any term or covenant of this Agreement or the application thereof to any person or circumstances shall, to any extent, be held invalid or unenforceable, the remaining terms and covenants of this Agreement, or the application of such term or covenant to persons or circumstances other than those as to which it is held invalid or unenforceable, shall not be affected thereby, and each term and covenant of this Agreement shall be valid and enforceable to the fullest extent permitted by law.

20.4 Right to Enforce Strictly. Any law, usage or custom to the contrary notwithstanding, PAID shall have the right at all times to enforce all terms, conditions and covenants of this Agreement in strict accordance with its terms, notwithstanding any conduct or custom on the part of PAID in refraining from so doing at any time or times, or from enforcing PAID’s rights hereunder strictly in accordance with the same. Any such conduct shall not be construed as having created a custom in any way or manner contrary to any specific term, condition or covenant of this Agreement, or as having in any way or manner modified the same.

- 20.5 Headings. The titles of the Sections are for convenience only, are not a part of this Agreement, and do not in any way define, limit, describe or modify the scope, intent or terms of this Agreement. Any reference herein to a Section shall be deemed to refer to the applicable Section of this Agreement unless otherwise expressly stated herein. Any reference to an Exhibit shall be deemed to refer to the applicable Exhibit attached hereto, all such Exhibits being incorporated herein and made a part hereof by this reference.
- 20.6 Signatures and Execution of Agreement. This Agreement is binding and effective only if it is fully executed by both parties.
- 20.7 Effect of Drafting on Construction. The fact that this document may have been initially drafted by the attorney for one of the parties hereto has no significance as to construction of ambiguous terms against either party, inasmuch as this Agreement is the product of arms-length negotiations between the parties, and no provision of this Agreement shall be construed against a party solely because that party or that party's counsel drafted such provision.
- 20.8 No Modification. This writing, along with the other Wireless Philadelphia Transactional Documents, is intended by the parties as a final expression of their agreement and as a complete and exclusive statement of the terms thereof, all negotiations, considerations and representations between the parties having been incorporated herein. No prior agreement between the parties or their affiliates shall be relevant or admissible to determine the meaning of any of the terms of this Agreement. No representations, understandings, or agreements have been made or relied upon in the making of this Agreement other than those specifically set forth herein and in the other Wireless Philadelphia Transactional Documents. This Agreement can be modified only by a writing signed by both parties hereto, approved by the City in accordance with Applicable Laws.
- 20.9 Waiver of Jury Trial. PAID AND CITY EACH HEREBY WILLINGLY, KNOWINGLY AND VOLUNTARILY WAIVES ANY AND ALL RIGHTS TO REQUEST A JURY TRIAL IN ANY PROCEEDING AT LAW OR IN EQUITY ARISING UNDER OR IN CONNECTION WITH THIS AGREEMENT.
- 20.10 Multiple Counterparts. This Agreement may be executed in one or more counterparts, each of which shall be deemed an original, but all of which together shall constitute one and the same instrument.

APPROVED AS TO FORM
Romulo L. Diaz, Jr. City Solicitor

CITY OF PHILADELPHIA

By: _____
Name: Michael C. Athay
Title: Divisional Deputy City Solicitor

By: _____
Name: Pedro A. Ramos
Title: Managing Director

Date: _____

Corporate Seal

**PHILADELPHIA AUTHORITY FOR
INDUSTRIAL DEVELOPMENT**

Date: 02/21/2006

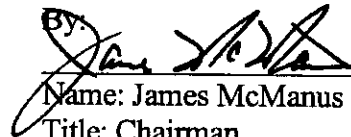
By: 
Name: James McManus
Title: Chairman

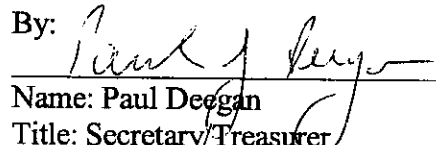
By: 
Name: Paul Deegan
Title: Secretary/Treasurer

APPROVED AS TO FORM
Romulo L. Diaz, Jr. City Solicitor

By: Michael C Ath
Name: Michael C. Athay
Title: Divisional Deputy City Solicitor

Corporate Seal

Date: _____

CITY OF PHILADELPHIA

By: [Signature]
Name: Pedro A. Ramos
Title: Managing Director

Date: 2/21/2006

**PHILADELPHIA AUTHORITY FOR
INDUSTRIAL DEVELOPMENT**

By: _____
Name: James McManus
Title: Chairman

By: _____
Name: Paul Deegan
Title: Secretary/Treasurer

EXHIBIT A

EARTHLINK/PAID STREET LIGHT USE AGREEMENT

EXHIBIT A

EARTHLINK/PAID STREET LIGHT USE AGREEMENT

STREET LIGHT USE AGREEMENT

This Street Light Use Agreement ("Agreement") is made and entered into on this twenty-first day of February, 2006 by and between the Philadelphia Authority for Industrial Development ("PAID") and EarthLink, Inc., a Delaware Corporation ("EL" or "EarthLink"), with offices at 1375 Peachtree Street, Level A, Atlanta, GA 30309. The Agreement shall be effective as of the "Effective Date," as defined in Section 1, *Definitions*. PAID and EL may be referred to individually as a "Party" and collectively as the "Parties."

BACKGROUND

WHEREAS, extraordinary and unparalleled advances in technology relating to internet communication have had, and have the potential to expand, a profound effect on business and commerce, education and the lives of ordinary citizens;

WHEREAS, the ability to connect via the worldwide web offers accelerated access to information and the exchange of ideas, creating enormous opportunities for economic development, delivery of more efficient municipal services and for disadvantaged children and adults to realize their potential;

WHEREAS, the City has determined that the safety, general welfare, economic development and prosperity of the people of Philadelphia are dependent upon accelerated technological improvements to the communications systems available in the City and accessibility of those improvements to the broadest segments of the population;

WHEREAS, the City has determined to act as a catalyst to encourage, promote, and attract expanded communications systems within the City, and most particularly to develop a city-wide wireless network;

WHEREAS, the City has determined that this network alone will be insufficient to afford full internet accessibility to low income residents, but that programs focusing on hardware and software availability as well as education and training are also necessary;

WHEREAS, the City desires to foster and stimulate collaboration between and among private entrepreneurs, non-profit agencies and government to afford the broadest range of benefits of internet advances to the general public through a business model which will appropriately allocate the risks and rewards of city-wide internet deployment;

WHEREAS, the Philadelphia Authority for Industrial Development is a public instrumentality of the Commonwealth of Pennsylvania organized under the Pennsylvania Economic Development Financing Law, Act No. 102, approved April 23, 1967, as amended, for the purposes, among others, of promoting the installation and use of the most efficient means of

communications, promoting public and private infrastructure, and promoting industrial, commercial and other economic development in the City of Philadelphia;

WHEREAS, the City has determined that fostering the growth of a city-wide wireless network will be best accomplished by implementing a business model which will utilize municipally-owned assets for deployment and operation of such a network are made available to a locally-controlled not-for-profit corporation, Wireless Philadelphia;

WHEREAS, Wireless Philadelphia has determined that the implementation of such network will be best accomplished by partnering with a private entrepreneur;

WHEREAS, to support this business model, the City desires to grant to the Authority certain rights for the placement of wireless communications equipment on certain municipally-owned street light fixtures, referred to herein as the Street Lights, and to authorize the Authority to authorize EarthLink, a for-profit corporation with substantial business expertise as an internet service provider and a developer of municipal wireless networks, to use the Street Lights for the placement of such equipment as provided in this Agreement;

WHEREAS, in consideration for such right to use the Street Lights, the City will receive street light use fees, funding for certain costs, free and discounted service rights, and Wireless Philadelphia will receive portions of the revenues generated by EarthLink for the operation of its programs to lower the cost of internet access and to provide citizens of Philadelphia with the knowledge, training, and equipment to benefit from the area-wide network and to otherwise manage its operations;

WHEREAS, the Authority and EarthLink desire to enter into this Agreement to provide for EarthLink's right to use the Street Lights as provided herein, and the other terms and conditions regarding the city-wide network, upon approval by City Council of this Agreement and an underlying agreement between the City and the Authority.

NOW, THEREFORE, in consideration of the above referenced recitals and the following mutual covenants, agreements, and obligations of the Parties, which constitute good and valuable consideration, the sufficiency of which is acknowledged, and with the intention to be legally bound hereby, PAID and EL agree as follows:

1 Definitions.

Capitalized words in this Agreement shall have the meaning defined below and if not defined herein then the meaning defined in the Network Agreement.

1.1 "Accepted" is defined in Section 3.4(b) of the Network Agreement.

1.2 "Acceptance Criteria" is defined in Section 3.1(a) of the Network Agreement.

1.3 "Affiliates" is defined in Section 9.3.1.

1.4 "Agreement" is this Street Light Use Agreement between PAID and EarthLink unless specific reference to a different agreement is made.

- 1.5 “Alternate(s)” is defined in Section 3.2.2.
- 1.6 “Alternate Street Light(s)” is defined in Section 3.2.2.
- 1.7 “Alternative Service” is defined in Exhibit I - Section 16 of the Network Agreement.
- 1.8 “Applicants” is defined in Section 3.1.1.
- 1.9 “Approved Updated Equipment” is defined in Section 2.4.2.
- 1.10 “As-Built Information” is defined in Section 4.2.1.
- 1.11 “Authorized Uses” is defined in Section 2.1.
- 1.12 “Bankruptcy Event” is defined in Section 7.4.
- 1.13 “Base Service” is defined in Exhibit A of the Network Agreement.
- 1.14 “Bulk Permit” is defined in Section 3.2.3.
- 1.15 “Bulk Construction Permit” means a Bulk Permit.
- 1.16 “Cable Franchise” is defined in Section 2.3.
- 1.17 “Cable Service” is defined in Section 2.3.
- 1.18 “City” means the City of Philadelphia, Pennsylvania.
- 1.19 “City/PAID Street Light Use Agreement” or “City/PAID Agreement” means the Street Light Use Agreement between PAID and the City of Philadelphia dated February 21, 2006 and signed February 21, 2006, pursuant to which the City approved this Agreement and consented to PAID’s entering into this Agreement to authorize EL to use Street Lights as provided in this Agreement.
- 1.20 “Commissioner” or “Streets Commissioner” means the Commissioner of the Philadelphia Streets Department.
- 1.21 “Communications Equipment” means, collectively, the Tropos 5210 Radio and Motorola Canopy Radio and the Approved Updated Equipment.
- 1.22 “Confidential Information” is defined in Section 13.
- 1.23 “Construction Permit” means a permit issued by the City Department of Streets authorizing EL to install and maintain Communications Equipment on Street Lights as provided in Section 3.

- 1.24 “Coverage Area” is defined in Section 4.5 of the Network Agreement.
- 1.25 “Core ISP Services” are the Services set forth in Exhibit J of the Network Agreement.
- 1.26 “CPE” or “Customer Premises Equipment” means equipment that end users are required to provide in order to access the Wireless Network.
- 1.27 “City Council” means the City Council of Philadelphia.
- 1.28 “Dark” and “Dark Day” are defined in Section 12.1.3.
- 1.29 “Day,” whether capitalized or not capitalized, means calendar day unless expressly provided otherwise.
- 1.30 “Design Concern Notice” is defined in Section 3.1(b) of the Network Agreement.
- 1.31 “Design Control Documents” is defined in Section 3.1(a) of the Network Agreement.
- 1.32 “Designated Street Light” is defined in Section 3.2.2.
- 1.33 “Digital Inclusion Areas” are those portions of the City identified on Exhibit E of the Network Agreement.
- 1.34 “Dispute” and “Dispute Resolution Period” are defined in Section 10.2.
- 1.35 “Earthlink” means EarthLink, Inc.
- 1.36 “EDPA” is defined in Section 17.19.
- 1.37 “Effective Date” means the later of (i) the date first written above, (ii) the date on which this Agreement and the City/PAID Agreement are fully executed, or (iii) the date on which an ordinance of City Council approving the City/PAID Agreement, to which this Agreement is attached as Exhibit A, becomes law.
- 1.38 “EL” means EarthLink.
- 1.39 “EL Assisted Wi-Fi” is defined in Exhibit I – Section 3 of the Network Agreement.
- 1.40 “EL Retail Wi-Fi” is defined in Exhibit I – Section 2 of the Network Agreement.
- 1.41 “EL Roaming Wi-Fi” is defined ins Exhibit I – Section 4(d) of the Network Agreement.
- 1.42 “Final Acceptance” is defined in Section 3.4(d) of the Network Agreement.
- 1.43 “Finally Accepted” means the occurrence of Final Acceptance.
- 1.44 “First Payment Conditions” is defined in Section 4.1 of the Network Agreement.

- 1.45 “Force Majeure Events” is defined in Section 17.31.
- 1.46 “Future Products” are any access product offerings, in which the primary functionality shall be wireless broadband connectivity made available via the System, that are not set forth in Exhibit I of the Network Agreement (not including the reference to Future Products in Exhibit I of the Network Agreement).
- 1.47 “Implementation” is defined in Section 3.4 of the Network Agreement.
- 1.48 “Implementation Conditions” is defined in Section 4.3 of the Network Agreement.
- 1.49 “Indemnitees” is defined in Section 9.3.1.
- 1.50 “Initial Term” is defined in Section 11.1
- 1.51 “Motorola Canopy Radio” is defined in Section 2.4.1.
- 1.52 “Muni T1” is municipal T1 wireless service provided pursuant to Section 7.1.3.2.
- 1.53 “Muni Wi-Fi” is municipal broadband wireless service accounts provided pursuant to Section 7.1.3.1.
- 1.54 “Network” means the System as defined in the Network Agreement.
- 1.55 “Network Access Point” means the Motorola Canopy Access Point radio to which the Motorola Canopy Radio connects to create a wireless backhaul connection.
- 1.56 “Network Agreement” means the Wireless Philadelphia Broadband Network Agreement of even date herewith between Wireless Philadelphia and EarthLink, Inc.
- 1.57 “Network Construction Plan” is defined in Section 4.1.3.
- 1.58 “Network Operations” is defined in Section 9.3.1.
- 1.59 “Non-Termination Defaults” is defined in Section 12.3.
- 1.60 “OA Wi-Fi” is defined in Exhibit I – Section 4 of the Network Agreement.
- 1.61 “OVS Franchise” is defined in Section 2.3.
- 1.62 “OVS Service” is defined in Section 2.3.
- 1.63 “PAID” or the “Authority” means the Philadelphia Authority for Industrial Development.
- 1.64 “Party” means either of the PAID or EarthLink.

- 1.65 “Parties” means both PAID and EarthLink.
- 1.66 “PECO” means Exelon Corporation.
- 1.67 “Permittee(s)” is defined in Section 3.1.1.
- 1.68 “Permits” means Construction Permits.
- 1.69 “Person” means any individual natural person, firm, partnership, joint venture, entity, society, organization, club, association, trustee, trust, corporation, company or organization of any kind.
- 1.70 “PIDC” means the Philadelphia Industrial Development Corporation, a nonprofit corporation organized under the laws of Pennsylvania for the purpose, among others, of assisting PAID in carrying out PAID’s economic development and other purposes.
- 1.71 “POC Construction Plan” is defined in Section 4.1.2.
- 1.72 “Preliminary Design Review” is defined in Section 3.1(a) of the Network Agreement.
- 1.73 “Proof of Concept Acceptance” is defined in Section 3.2 (c) of the Network Agreement.
- 1.74 “Proof of Concept Conditions” is defined in Section 4.2 of the Network Agreement.
- 1.75 “Proof of Concept Trial” is defined in Section 3.2(d) of the Network Agreement.
- 1.76 “Proof of Concept Permits” is defined in Section 4.2(b) of the Network Agreement.
- 1.77 “Renewal Terms” is defined in Section 11.2.
- 1.78 “Request for Internal Resolution” is defined in Section 10.2.
- 1.79 “Revenue Share” means the payments made to WP as provided in the Network Agreement.
- 1.80 “Right-of-Way” has the meanings provided in Chapter 11-700 of The Philadelphia Code.
- 1.81 “Right-of-Way Use License” has the meaning provided in Chapter 11-700 of The Philadelphia Code.
- 1.82 “Schedule” is defined in Section 2 of the Network Agreement.
- 1.83 “Streets Department” means the Department of Streets of the City.
- 1.84 Reserved.
- 1.85 “Street Light” means the City-owned street light fixture and attached photocell, together with the lateral arm, overhanging the street and/or sidewalk, on which the light fixture is

mounted. "Street Light" does not mean or include any pole (whether or not owned by the City) to which the lateral arm and light fixture are attached.

- 1.86 "Streets Commissioner" means the Commissioner of the Department of Streets of the City.
- 1.87 "Subcontractor" means any contractor of EL and/or of any EL contractor, at any tier, that performs work on the Wireless Network, whether or not EL is directly in contract therewith.
- 1.88 "System" means the Wireless Network.
- 1.89 "System Acceptance" is defined in Section 3.4(e) of the Network Agreement.
- 1.90 "T1 Alternative Product" is defined Exhibit I of the Network Agreement.
- 1.91 "Term" and "term of this Agreement" mean the Initial Term and any Renewal Terms.
- 1.92 "Termination Default(s)" is defined in Section 12.1.
- 1.93 "Three Important SLAs" are items 1, 2 and 5 set forth in Exhibit F under "Performance Requirements" of the Network Agreement.
- 1.94 "Three Important SLAs Failure Notice" is defined in Section 16.4(a) of the Network Agreement.
- 1.95 "Tropos 5210 Radio" is defined in Section 2.4.1.
- 1.96 "Wi-Fi Broadband Product" is defined Exhibit I of the Network Agreement.
- 1.97 "Wireless Network" or "System" means the City wide wireless broadband Internet access system that EL will design, build, install, test, operate, maintain and upgrade as provided in the Network Agreement; the Wireless Network to be in accordance with Exhibit B, *Network Description*, hereto and Exhibit F, *Requirements*, to the Network Agreement, as such Exhibits may be amended pursuant to the Network Agreement.
- 1.98 "WP" means Wireless Philadelphia.
- 1.99 "WP Mission" is defined in Section 1.5 of the Network Agreement.
- 1.100 "Zone" is defined in Section 3.4(a) of the Network Agreement.

2 Authorization.

- 2.1 Scope of Authorization. Subject to the terms and conditions of this Agreement and for the term provided in Section 11, *Term, Renewal, Expiration and Removal*, PAID authorizes EL to install, repair, replace, operate, maintain, and use Communications Equipment on the Street Lights for which the City has issued Construction Permits in accordance with

Section 3, *Application and Approval to Place Communications Equipment* (collectively, the "Authorized Uses"). Neither EL nor its Subcontractors may use or perform any activity on any Street Light without first obtaining a Construction Permit for that Street Light in accordance with Section 3, and nothing in this Section 2 or elsewhere in this Agreement shall be construed to limit or excuse such requirement to obtain a Construction Permit. EL's authorization to use Street Lights shall terminate upon the termination of this Agreement in accordance with its terms. Nothing in this Agreement shall authorize or convey any right to EL to install Communications Equipment or other equipment on or otherwise to use any pole to which a Street Light is attached, whether or not the pole is owned by the City.

- 2.2 **Authorization Not Exclusive.** The authorizations granted in this Section 2 shall be non-exclusive and nothing contained in this Agreement shall be construed to limit, alter, or waive the right of PAID or the City to enter into agreements authorizing persons or entities other than EL to access and use Street Lights to install any form of communications equipment or for any other purpose. Such authorizations by the City or PAID shall be made on a non-discriminatory and competitively neutral basis, taking into account material differences in the circumstances of each applicant for such authorization.
- 2.3 **Cable Service and OVS Service.** EL shall not provide Cable Service or OVS Service by means of the Wireless Network without first obtaining a Cable Franchise or OVS Franchise as required by Section 11-703, *Cable Franchise; Open Video System Franchise*, of the Philadelphia Code, as amended; such obligation is subject to the enforceability of Section 11-703 under applicable law. EL shall obligate its wholesale customers to comply with the foregoing sentence, shall enforce the obligation, and shall incorporate in its service agreements with such customers a provision substantially the same as this Section 2.3. The terms "Cable Service," "OVS Service," "Cable Franchise," and "OVS Franchise," as used in this Section 2.3 and elsewhere in the Agreement, shall have the meanings provided for them in Section 11-701, *Definitions*, of The Philadelphia Code.
- 2.4 **Authorized Communications Equipment and Installation Method; Upgrades.**
- 2.4.1 EL is authorized to place on Street Lights the following Communications Equipment: The Tropos Model 5210 Outdoor MetroMesh Router radio device depicted in Exhibit A (the "Tropos 5210 Radio") and the three Motorola Canopy Broadband Wireless Subscriber Module radio devices depicted in Exhibit A (collectively, the "Motorola Canopy Radio"). The method of installation shall be as depicted in Exhibits A. In no event may any part of the Street Light be penetrated by any radio device, cable, mounting device, or other Communications Equipment. Electrical power shall be obtained only by attaching an adapter and cable to the Street Light photo cell, in the manner depicted in Exhibit A. Except as authorized by the Streets Commissioner in writing, no other item of Communications Equipment (including without limitation upgraded or updated versions of Communications Equipment) or other equipment or material may be placed on any Street Light; no other method of installation may be employed; and no other means of obtaining electrical power for Communications Equipment installed on the Street Lights may be used.

- 2.4.2 Authorization of the Streets Commissioner to replace authorized Communications Equipment with updated or upgraded Communications Equipment shall be required prior to installation but will not be unreasonably withheld provided the replacement equipment (i) is no heavier or larger and uses no more electrical power than the Tropos 5210 Radio and/or Motorola Canopy Radio(s), and uses the same method of obtaining electrical power as those two radio devices; and (ii) the electrical power consumption, size and weight of the updated equipment does not, in the reasonable judgment of the Streets Commissioner, place an unacceptable burden or risk on the Street Lights (equipment satisfying all of the foregoing requirements is referred to herein as "Approved Updated Equipment"). The installation of Approved Updated Equipment in substitution of Communications Equipment for which Construction Permits have been issued by the Streets Commissioner shall not normally require the issuance of new Construction Permits provided the Approved Updated Equipment is placed on a Street Light for which a Construction Permit has been issued. Notwithstanding the foregoing, such installations shall be removed or altered as directed by the Streets Commissioner if, upon inspection, they are determined by the Streets Commissioner to be noncompliant with the requirements of the Construction Permit originally issued or the requirements of this Agreement. Software upgrades to the Wireless Network that do not require replacement or modification of any Communications Equipment apart from the installation of the software remotely through the Wireless Network may be performed without prior approval of the Commissioner; provided, however, that if the Streets Commissioner requests notifications prior to software upgrades, EL shall provide the requested notification.
- 2.4.3 Except as authorized by the Streets Commissioner in writing, not more than one (1) Tropos 5210 Radio and not more than one Motorola Canopy Radio may be attached to any Street Light; provided, however, that different radio devices may be substituted for these devices as part of an upgrade of the Communications Equipment in accordance with Sections 2.4.2 and 2.4.4. The City will not, subsequent to issuing EL a Construction Permit for its use of a Street Light, authorize other persons or entities to place radio devices on the Street Light if the Streets Commissioner reasonably determines that such additional radio device(s) will cause radio frequency interference or physical interference with the operation of the EL radio device(s) for which a Construction Permit was issued.
- 2.4.4 In no event may EL or any of its Subcontractors install or construct new Street Lights or modify or repair existing Street Lights except as may be expressly authorized by this Agreement or by a Construction Permit issued pursuant to Section 3, or otherwise authorized in writing by the Streets Commissioner.
- 2.4.5 In no event may EL or any of its Subcontractor(s) attach any Communications Equipment or any other device or material to a Street Light, or modify the location or method of attachment, except as expressly authorized by this Agreement or by a Construction Permit issued pursuant to Section 3, *Application and Approval to Place Communications Equipment*, or is otherwise authorized in writing by the Streets Commissioner. Upgrades of Communications Equipment that require the replacement of the equipment or any appurtenant equipment shall not be made unless authorized in writing by the

Commissioner in accordance with Section 2.4.1, and, if deemed reasonably necessary by the Streets Commissioner, a Construction Permit pursuant to Section 3 is issued therefor.

- 2.5 Conditions of City Issuance of Construction Permits. The City's issuance of new Construction Permits to EL under this Agreement is conditioned on EL's compliance with the following Sections 2.5.1-2.5.7 at all times during the Initial Term and any Renewal Terms of this Agreement. EL's failure to comply with such conditions shall constitute a Non-Termination Default under Section 12, *Default and Termination*, and shall entitle the City to exercise the remedies set forth therein, including, without limitation, the remedy of denying new applications for Construction Permits set forth in Section 12.2; provided, however, that Construction Permits will not be denied except for EL's persistent failure to comply (as reasonably determined by the Streets Commissioner) after written notice of noncompliance by the Streets Department; and provided further that EL may, after taking appropriate action to ensure future compliance, apply to the Streets Commissioner for reinstatement of the issuance of Construction Permits.
- 2.5.1 EL shall comply with the terms of this Agreement.
- 2.5.2 The Streets Commissioner shall have issued a Right-of-Way Use License, in accordance with Chapter 11-700 of The Philadelphia Code, to EL, as the owner of Communications Equipment placed on Street Lights, and/or to each of EL's Subcontractor(s) that owns or will own Communications Equipment placed on the Street Lights.
- 2.5.3 EL shall obtain, prior to commencing installation or operation, all applicable permits, licenses, and authorizations from the City, Commonwealth of Pennsylvania, and the federal government for the installation and operation of the Wireless Network and such authorizations have not been terminated or revoked.
- 2.5.4 EL and its Subcontractors shall comply with Section 2.14, *Compliance With Law*.
- 2.5.5 Reserved.
- 2.5.6 EL shall pay to PAID for the account of the City and to WP, as applicable, all compensation required under Section 7, *Compensation*, of this Agreement and/or under the Network Agreement when due in accordance with the terms thereof.
- 2.5.7 The conditions provided in Section 2.7, *Conditions of the Obligations of the Parties*, are satisfied and neither party has terminated the Agreement pursuant to Section 2.7.7, *Termination*.
- 2.6 Maximum Number of Street Lights Authorized. EL shall be authorized to access and to use, pursuant to this Agreement, a total of not more than five thousand (5,000) Street Lights throughout the City and shall not access or use more than that number of Street Lights; provided, that the Streets Commissioner, in her sole discretion and upon application by EL, may authorize EL's use of additional Street Lights in excess of five thousand (5,000).

2.7 Conditions of the Obligations of the Parties. The obligations of PAID and EL hereunder shall be subject to the following conditions:

2.7.1 This Agreement has been approved and fully executed by all Parties through fully authorized representatives.

2.7.2 The Philadelphia City Council has approved by ordinance such agreements between the City and PAID as may be required to authorize PAID to enter into this Agreement and give to EL the rights to use Street Lights that are provided in this Agreement, and such ordinance has become law.

2.7.3 PECO will furnish electricity service to the Communications Equipment installed on Street Lights and in a manner that the Parties agree complies with applicable laws and regulations.

2.7.4 EL is not prohibited from constructing and operating the Wireless Network, or performing substantially all of the services or exercising substantially all of the rights set forth in this Agreement by the final decision, following exhaustion of all appeals, of a court of competent jurisdiction, or by the enactment into law of a valid and enforceable federal, state, or local statute.

2.7.5 EL has obtained all applicable permits, licenses, and authorizations from the City, Commonwealth of Pennsylvania, and the federal government for the installation and operation of the Wireless Network, and such authorizations have not been terminated or revoked and are no longer subject to appeal; provided, that EL may not, on account of the failure of this condition to be satisfied, terminate the Agreement under Section 2.7.7 unless EL has exercised every commercially reasonable effort to obtain all such permits, licenses, and authorizations; and PAID may not so terminate the Agreement if the City has unreasonably withheld such authorizations that are required from the City and within the City's control to issue.

2.7.6 Proof of Concept Acceptance has occurred pursuant to Section 3.2(c) of the Network Agreement, and the City and WP has each issued its written acceptance of the Proof of Concept in accordance with the procedures provided in Section 3.2(c) of the Network Agreement. The City shall have the right to participate in the Proof of Concept Acceptance process as provided in Section 3.2(c) of the Network Agreement.

2.7.7 Termination.

2.7.7.1 Either Party shall be entitled, but not obligated, to terminate this Agreement without penalty or liability to the other Party if, on the day that is one hundred and eighty (180) days after the later of (i) the date on which the ordinance of City Council approving the City/PAID Agreement to which this Agreement is attached as Exhibit A has become law, (ii) the Effective Date, or (iii) the date on which the Agreement is fully executed, the conditions set forth in Sections 2.7.1-2.7.6 are not completed and satisfied, and such failure to complete and satisfy was not caused by the terminating Party; provided, however, as follows: a party shall terminate under this Section by delivering its written notice of termination to the other Party and to the City within

ninety (90) days following the end of such one hundred and eighty (180) day period; the Agreement shall remain in full force and effect throughout the ninety (90) day notice period and shall terminate on the last day of the notice period unless such conditions are completed and satisfied by the end of the ninety (90) day notice period, or the Agreement is sooner terminated by the written agreement of both parties or in accordance with its terms.

2.7.7.2 In addition to the foregoing right of termination, either party shall be entitled, but not obligated, to terminate this Agreement without penalty or liability to the other Party if at any time during the Initial Term or any Renewal Terms of the Agreement, EL is prohibited from constructing and operating the Wireless Network, or the City, PAID, or EL is prohibited from performing substantially all of the obligations or exercising substantially all of the rights set forth in this Agreement, by the final decision, following exhaustion of all appeals, of a court of competent jurisdiction, or by the enactment into law of a valid and enforceable federal, state, or local statute. A Party that believes it has the right to terminate under this Section 2.7.7.2 may elect not to terminate without waiving its right to terminate. In the event of termination pursuant to this Section, EL shall remove the Communications Equipment and restore the Street Lights as provided in Section 11.3, *Expiration and Removal*, and the City shall have all the rights and remedies provided therein.

2.7.7.3 Notwithstanding anything to the contrary in this Section 2.7.7., (i) if the Network Agreement is terminated because Proof of Concept Acceptance is not achieved within the ninety (90) day period provided in Section 3.2(d) of the Network Agreement, then this Agreement shall terminate on the date the Network Agreement so terminates; and (ii) if City Council has not approved this Agreement and the City/PAID Street Light Use Agreement by ordinance (each in the form and content executed by all parties, dated February 21, 2006 and effective the Effective Date of this Agreement, and attached to the proposed ordinance as introduced in City Council), and/or the ordinance has not become law on or before the earlier of (x) the end of the Spring 2006 Council term or (y) July 1, 2006, then each Party shall have the right to terminate this Agreement with ten (10) days written notice to the other Party, with a copy to the City; provided, that such approval of this Agreement shall be the approval of the City/PAID Street Light Use Agreement with this Agreement attached as Exhibit A thereto. If a Party elects not to terminate under this Section 2.7.7.3 at the time it is entitled to do so, it shall not have waived its right to later terminate.

2.8 Except as expressly provided otherwise in this Agreement, nothing in the Agreement, or in any ordinance of City Council approving this Agreement, shall constitute an authorization to install, operate, maintain, repair, modify, or use Communications Equipment or any other device or material on a Street Light without first obtaining a Construction Permit as provided herein.

2.9 Nothing in this Agreement shall constitute a representation or warranty that the City or PAID has sought or obtained permission from any third-party property owner for EL's installation or operation of Communications Equipment or any other equipment on that third party's property unless the Communications Equipment is on Street Lights located in

the Right-of-Way. EL acknowledges and agrees that it shall be solely responsible for obtaining any such permission that may be required for its installation or operation of Communications Equipment that is not placed on Street Lights located in the Right-of-Way.

- 2.10 Neither EL's occupancy nor its use of Street Lights or the Right-of-Way, nor anything contained in this Agreement or in any Construction Permit issued by the City (i) shall grant, convey, create, or vest in EL any form of real property interest in any Street Light or other City personal property or real property or facility, or in any pole to which a Street Light is attached (whether or not owned by the City), or in any portion of the Right-of-Way, including, but not limited to, any fee or leasehold interest, any easement, or any franchise right therein; or (ii) create in PAID or the City any ownership interest in any Communications Equipment installed by EL on a Street Light, except as may be expressly provided in this Agreement.
- 2.11 EL acknowledges and agrees that neither PAID nor the City makes and has made no warranties or representations regarding the fitness, safety or suitability of the Street Lights or any City property or facility, or the Right-of-Way, for the installation or operation of the Communications Equipment or the Wireless Network; that EL is solely responsible for determining such fitness, safety, and suitability; and that any performance of work, costs incurred, and/or provision of services contemplated under this Agreement by EL is at EL's sole risk.
- 2.12 Wireless Internet access shall at all times throughout the Initial Term and any Renewal terms be offered over the Wireless Network; such access will be provided in the form of "Base Service" as defined and set forth in Exhibits A and I of the Network Agreement.
- 2.13 EL shall construct and operate the Wireless Network in accordance with the Network Agreement.
- 2.14 Compliance With Law. EL and its Subcontractors shall comply with all applicable federal, state, and local laws, ordinances and regulations, including, without limitation, Chapters 9-300, 11-200, and 11-700 of The Philadelphia Code, relating to management of the Right-of-Way; all other applicable provisions of The Philadelphia Code, and the Regulations of the Department of Streets and the Department of Public Property. Nothing contained in this Agreement shall limit or waive EL's obligation to comply with ordinances of general application of the City and provisions of general application of The Philadelphia Code that become law after the date first written above.

3 Application and Approval to Place Communications Equipment.

3.1 Construction Permits Required.

- 3.1.1 Neither EL nor its Subcontractors may place any Communications Equipment on any Street Light or use the Street Lights for any Authorized Use unless or until EL has applied for and the Streets Commissioner has issued a Construction Permit authorizing the

activity on that Street Light. (Parties applying for such Construction Permits are referred to in this Agreement as “Applicants” and recipients as “Permittee(s).”)

- 3.1.2 EL shall not, however, be required to obtain a Construction Permit to perform routine maintenance on Communications Equipment, or to replace an item of Communications Equipment with the same model of equipment provided (i) the model has been approved in writing by the Streets Commissioner in this Agreement or otherwise, (ii) the replacement device is no heavier or larger and uses no more electrical power than the model it is replacing, (iii) the method of obtaining electrical power for the device is the same as for the model it is replacing, and (iv) the electrical power consumption, size and weight of the updated equipment does not, in the reasonable judgment of the Streets Commissioner, place an unacceptable burden or risk on the Street Lights.
- 3.1.3 If EL has not installed Communications Equipment on a Street Light within one hundred and eighty (180) days after the issuance of a Construction Permit for the Street Light (or a longer period if provided in the Construction Permit), the Construction Permit shall be deemed expired as to that Street Light, and EL’s right to use the Street Light shall be terminated. EL may, however, apply for a new Construction Permit for any Street Light as to which a Construction Permit has expired and its use right terminated pursuant to this Section.

3.2 Permit Applications.

3.2.1 Information Required. Applications for Construction Permits shall contain the following information and plans, and such additional information as the Streets Commissioner may reasonably require in order to evaluate the proposed construction:

- The exact location of each Street Light on which the Applicant seeks to place Communications Equipment, identified by the pole identification number assigned to the pole in the Streets Department geographical information system database. The Streets Department will provide EL with sufficient information to comply with this requirement.
- Detailed specifications for each item of equipment to be placed on the Street Light, showing size, weight, mounting method, method of providing electrical power (including placement of any cables), and the method of attaching to the Street Light photo cell if required for electrical power.

3.2.2 Substitution. EL may apply for Construction Permits for more Street Lights than it intends to use for the placement of Communications Equipment in any block or blocks of the City, by designating, in its application, the intended Street Light (the “Designated Street Light”) and up to two alternate Street Lights (the “Alternate Street Light(s)” or “Alternate(s)”). If such permits are issued, the Permittee may substitute any one of the Alternates approved in the permit for the Designated Street Light, if substitution is necessary for proper coverage and operation of the Communications Equipment; but EL shall be deemed to have waived its right to use any of the permitted Street Lights on which it has not placed Communications Equipment within ninety (90) days of the

issuance of the permit. Within the times following installation provided in Section 4.2.2 (relating to submission of As-Built Information during initial construction), EL shall submit to the City as-built information, in form and content determined by the Streets Commissioner, that identifies the specific Street Light, Designated or Alternate, on which the Communications Equipment was installed. If authorized by the Streets Commissioner, substitutions of alternate Street Lights for Designated Street Lights may be approved in the field by authorized Streets Department inspectors whether or not the alternate Street Lights were approved in the permit.

3.2.3 Bulk Construction Permit Applications. EL may apply for a single Construction Permit that applies to up to one hundred and twenty-five (125) Designated Street Lights, plus up to two Alternates for each (a "Bulk Permit"); provided, that EL shall not apply for and the Streets Department shall not be obligated to process more than one Bulk Permit application per week without the written authorization of the Streets Commissioner. The application for a Bulk Permit must comply with all requirements of this Section 3. Section 3.2.2, *Substitution*, shall apply to Bulk Permits.

3.2.4 Time to Issue. For applications for up to ten (10) Street Lights, the Streets Department shall exercise reasonable efforts to issue Construction Permits or its rejection of the permit application within fourteen (14) days of receiving a complete application. For applications for Bulk Permits, the Streets Department shall exercise reasonable efforts to issue Construction Permits or its rejection of the application within thirty (30) days of receiving a complete application. Applications will not be unreasonably rejected.

3.2.5 Lane Closure Permits. EL or its Subcontractor(s) shall not close or block vehicular traffic in any traffic lane of a City street without first obtaining a lane closure permit or other authorization as required by the Streets Department.

4 Network Construction; Construction Plans.

4.1 Construction Plans; Organization of the Work.

4.1.1 Organization of the Work. EL shall schedule the work so that each construction crew completes the installation of Communications Equipment on all Street Lights authorized by a Bulk Construction Permit before that crew commences the installation of Communications Equipment on Street Lights authorized by a different Bulk Construction Permit. No construction crew shall at any time perform installations on Street Lights covered by two or more Bulk Construction Permit. Nothing in this Section 4.1.1 shall preclude EL from requesting or the Streets Commissioner from approving a different organization of the work.

4.1.2 Proof of Concept Construction Plan. EL shall submit to the Streets Commissioner its detailed plan for the construction of the Proof of Concept Trial ("POC Construction Plan") at least thirty (30) days prior to commencing construction of the network for the Proof of Concept Trial. The network for the Proof of Concept Trial shall cover a total area of approximately fifteen (15) square miles and shall be constructed as provided in the Network Agreement. The POC Construction Plan shall include the following

information, together with such additional information and plans as the Streets Commissioner may reasonably require:

- A detailed map, in electronic form and in a format reasonably required by the Streets Commissioner, depicting (i) each block of the City in which EL and its Subcontractor(s) intend to place Communications Equipment on Street Lights; the number of Street Lights in each block for which use is intended; and the locations (including whether a roof top or tower) for each Network Access Point to be constructed.
- A construction schedule depicting start date, completion date, and the sequence of construction for the POC Pilot area.

The POC Construction Plan, including without limitation the map and schedule, shall be updated and the updated Plan submitted to the Streets Commissioner at least every thirty (30) days throughout the construction of the POC Pilot network.

4.1.3 Wireless Network Construction Plan. EL shall submit to the Streets Commissioner its detailed plan for construction of the entire Wireless Network (the "Network Construction Plan") at least thirty (30) days prior to commencing construction for any part of the Wireless Network other than the Proof of Concept Trial (and any earlier constructed pilots authorized by the Streets Commissioner). The Network Construction Plan shall divide the geographical area of the City into at least five (5) Zones, approximately equal in geographical area and each consisting of contiguous City blocks. The Network Construction Plan shall include the following information, together with such additional information and plans as the Streets Commissioner may reasonably require:

- A detailed map, in electronic form and in a format reasonably required by the Streets Commissioner, depicting (i) each block of the City in which EL and its Subcontractor(s) intend to place Communications Devices on Street Lights; the number of Street Lights in each block for which use is intended; and the locations (including whether a roof top or tower) for each Network Access Point to be constructed.
- A construction schedule depicting the start and completion times for construction in each Zone, and the sequence of construction within each Zone.

The Network Construction Plan, including without limitation the map and schedule, shall be updated, and the updated Plan submitted to the Streets Commissioner, within thirty (30) days following completion of the Proof of Concept Trial, and every thirty (30) calendar days thereafter until construction of the entire Wireless Network is completed and Finally Accepted in accordance with the Network Agreement.

4.2 As-Built Information.

4.2.1 EL shall maintain and submit to the Streets Commissioner accurate, fully up-to-date as-built plans, maps, drawings and information identifying all Street Lights and other City

property and facilities in use by EL, including the Communications Equipment and any other equipment that is located on the Street Light or other property or facility owned or controlled by the City (the "As-Built Information"). In addition to the foregoing, the As-Built Information shall include, for each Street Light on which Communications Equipment is placed: the pole identification number assigned to the pole and Street Light in the Streets Department geographical information system database (the Streets Department will provide EL with sufficient information to comply with this requirement); the serial number, manufacturer, model number and device type (short description) of each item of equipment placed on the Street Light; the electrical power source; and the contact information required on the information tags provided in Section 5.9, *Information Tags*; and such additional information as the Streets Commissioner determines is necessary to manage EL's use of the Street Lights and the Right-of-Way. The As-Built Information shall be submitted in a format determined by the Streets Commissioner.

- 4.2.2 During the period of initial construction of the Wireless Network (i.e. the period from execution of the Network Agreement through Final Acceptance of the Wireless Network in accordance with the Network Agreement), EL shall submit the As-Built Information as follows: (i) On or before the Friday of each week, EL shall submit to the Streets Commissioner a map or other form of information approved by the Streets Commissioner that accurately identifies each Street Light on which EL placed Communications Equipment during the prior week, together with a description of the Communications Equipment installed; (ii) within ten (10) days following its completion of the installation of Communications Equipment in a Zone, EL shall submit to the Streets Commissioner As-Built Information (other than maps, plans and drawings) for the entire Zone, and shall submit maps, plans and drawings required as part of the As-Built Information within thirty (30) days following such completion.
- 4.2.3 Following Final Acceptance of the Wireless Network and throughout the term of this Agreement and any renewal term, EL shall submit revised and updated As-Built Information as follows for new installations of Communications Equipment and for relocations of existing installations to different Street Lights: (i) Within thirty (30) days following Final Acceptance, EL shall submit to the Streets Commissioner a map (or other form of information approved by the Streets Commissioner) that accurately identifies each Street Light on which EL placed Communications Equipment; (ii) within ten (10) days following any change from the last-submitted As-Built Information for a Zone, EL shall submit to the Streets Commissioner updated As-Built Information (other than maps, plans and drawings) for the entire Zone, and shall submit maps, plans and drawings required as part of the As-Built Information within thirty (30) days following such completion.

5 Installation And Maintenance.

5.1 Inspection.

5.1.1 Construction Inspection.

5.1.1.1 All construction activities relating to Street Lights and/or taking place in the Right-of-Way, including, without limitation, the installation of Communications Equipment on Street Lights, shall be subject to such inspections as the Streets Commissioner determines are necessary to ensure the construction complies with this Agreement, Streets Department regulations, and applicable provisions of The Philadelphia Code. In the event Streets Department inspection determines that such construction activities are noncompliant, EL shall promptly correct the noncompliance as directed by the Streets Department.

5.1.1.2 The Streets Department shall provide three dedicated full-time construction inspectors to accompany up to three EL installation crews throughout the construction of the Wireless Network, up to a maximum of twelve (12) months, subject to its ability to identify and retain the three inspectors in accordance with the City's hiring requirements. EL shall pay all Streets Department costs for the three inspectors and their inspection activities, up to a maximum of Three Hundred Thousand Dollars (\$300,000). The Streets Department will submit invoices to EL for such inspection costs periodically, in a manner and with such documentation as is reasonably determined by the Streets Commissioner and EL. If more than three EL construction crews operate concurrently, or if the Streets Department is unable to identify and retain the three inspectors in accordance with City hiring requirements, EL shall be responsible for providing inspection services, through a third party contractor approved by the Streets Commissioner and in accordance with Streets Department inspection requirements, at EL's cost.

5.1.2 Safety Inspections. The Streets Department shall have the right to conduct such inspections of the Communications Equipment and other EL facilities and equipment located on Street Lights, at other City-owned or City-controlled sites or facilities, and/or in the Right-of-Way, as the City deems reasonably necessary in order to ensure the safety thereof, compliance with this Agreement and applicable Construction Permits, and the health, safety, and welfare of the public, including, without limitation, periodic safety inspections by the Streets Department of Communications Equipment located on Street Lights. The City shall have full access to the Communications Equipment.

5.2 Removal of Previous Installations. If, during installation of Communications Equipment on a Street Light, EL encounters a device previously installed by others, it may apply to the Streets Commissioner for authority to remove the device. In no event shall any such device be removed without the written approval of the Streets Commissioner, and in no event shall EL or its Subcontractors remove any such device that is operating and in use by its owner.

5.3 Removal for City Work. The City shall have the right to require EL to temporarily or permanently remove or relocate its Communications Equipment and/or any other

equipment located on Street Lights or other City property if the removal or relocation is necessary to accommodate the construction, completion, repair, relocation or maintenance of a City project, or in the event the City replaces, repairs, or alters a Street Light on which EL has placed Communications Equipment. The Streets Commissioner shall notify EL thirty (30) days before the date on which removal or relocation is required to commence, and shall provide a longer notice period where the Commissioner reasonably determines that a longer notice period is necessary or appropriate for the work required. EL shall complete such removal or relocation, at EL's sole cost and expense, after written notice from the Streets Department and within a period of time reasonably determined by the Streets Commissioner, which shall be at least thirty (30) days. If EL does not comply with this Section 5.3, the City may remove or relocate the Communications Equipment or other equipment at EL's expense. If EL is directed, under this Section 5.3, to remove its Communications Equipment from a Street Light it is authorized to use, EL may elect to relocate, replace, or transfer some or all of the Communications Equipment to replacement Street Lights, at EL's cost and subject to the Streets Commissioner issuing Construction Permits, if required by the Commissioner, for the proposed replacement Street Light(s).

5.4 Emergency Action. The Streets Commissioner shall have the right to require the immediate removal, relocation, replacement, or transfer of Communications Equipment in the event the Commissioner determines that an emergency condition, as reasonably determined by the Commissioner, requires such action. In such event, the Commissioner shall promptly inform EL that such action is required and EL shall immediately complete the action required by the Commissioner. If the Commissioner determines there is a threat to the public health, safety, or welfare, the Streets Department shall have the right to remove, relocate, replace, or transfer the Communications Equipment at EL's expense. Absent such threat, the Streets Department shall not itself relocate, replace, or transfer the Communications Equipment without EL's prior written consent.

5.5 Damaged or Destroyed Street Lights.

5.5.1 If a Street Light or Street Light pole is damaged or destroyed to such an extent that EL or its Subcontractors cannot safely or lawfully maintain its operations at its then current level using that Street Light or pole, then the Party that first becomes aware of the problem shall provide the other Party, the Streets Commissioner, and PECO, if the condition affects a PECO owned pole or the electrical power supply, with written notice of this circumstance within a reasonable period after the damage, destruction, or inability to maintain operations. The Streets Commissioner shall then have thirty (30) days to advise EL in writing as to whether the City intends to restore or replace the applicable Street Light or pole, if the pole is owned by the City, and how long such replacement will take. If the pole is owned by PECO, the Commissioner shall exercise reasonable efforts to determine whether PECO intends to restore or replace the pole and will notify EL in writing of PECO's intention within thirty (30) days of PECO's notice to the Commissioner as to its intention. If the Streets Department advises EL that neither it nor PECO intends to restore or replace the affected Street Light or pole within thirty (30) days from the Commissioner's notice, EL shall have the right to designate a substitute Street Light for the affected Communications Equipment and request, in writing, the Commissioner's approval to relocate its equipment to the designated Street Light. Within

thirty (30) days after its receipt of EL's written request, the Streets Department shall notify EL whether it will permit EL to relocate its Communications Equipment to the substitute Street Light. Provided the requested Street Light(s) are not being used by others and satisfy the requirements of this Agreement, the Streets Department's approval will not be unreasonably withheld. EL shall be solely responsible for the cost of transferring Communications Equipment to the substitute pole and any costs required to make the pole ready for installation.

- 5.5.2 If the Streets Department elects not to repair or replace the destroyed or damaged Street Light or (where owned by the City) pole within thirty (30) days, then EL's right to use the Street Light and pole shall terminate, effective as of the date the Street Light and/or pole became unusable for the Communications Equipment. EL shall be entitled to a pro-rata abatement of the fee provided in Section 7.1.2, *Monthly Street Light Use Fee* for the affected Street Light for the number of twenty-four (24) hour periods it is unable to conduct its normal operations from the affected Street Light or the substitute Street Light, but shall otherwise be obligated to pay the fee provided in Section 7.1.2 for each such period that it uses or has access to a Street Light for the installation of Communications Equipment.
- 5.5.3 If the Streets Department elects to repair or replace the original Street Light or Street Light pole after the deadlines specified above have expired, then it shall provide notice thereof to EL. Subject to the Streets Commissioner's approval of its use of the original Street Light or its continued use of the substitute Street Light, whichever is applicable, EL shall then have thirty (30) days after the restoration or replacement has been completed to either (i) transfer the Communications Equipment back to the original Street Light and reinstate this Agreement as to the original Street Light; or (ii) notify the Commissioner that it will continue to maintain the Communications Equipment on the substitute Street Light pursuant to this Agreement.
- 5.5.4 No Obligation to Replace, Construct or Improve Street Lights. Neither PAID nor the City shall have any obligation to construct new Street Lights (including poles and appurtenant equipment), or to replace, repair, modify, upgrade, or improve any Street Light (including poles and appurtenant equipment).
- 5.5.5 Restoration. EL shall, at its own expense, promptly restore to its original condition or a better condition, in accordance with City regulations and standards generally applicable to such work, any street or Right-of-Way affected by any work authorized under this Agreement and/or any Construction Permit issued by the City, including both the sidewalk and roadway, and any street light fixture, street light pole, traffic signal pole or other City property affected, all as reasonably required by the Streets Commissioner. During the construction of the Wireless Network, EL shall perform such restoration, and the restoration of all work site areas to a clean and safe condition, upon the completion of each task, installation and phase of the work as set forth in the Construction Plans and schedules provided in Section 4, *Network Construction; Construction Plans*. Such restoration shall in each case be completed within a time reasonably required by the Streets Commissioner.

- 5.5.6 Removal of Communications Equipment. If EL removes the Communications Equipment from any Street Light(s) (except pursuant to Section 5.3, *Removal for City Work*, or Section 5.4, *Emergency Action*), then EL shall provide the Streets Commissioner written notice of such removal within thirty (30) days, specifying the Street Light(s) vacated, the exact locations thereof, and the date of removal. Removal of all Communications Equipment from any Street Light without its replacement or substitution by EL within thirty (30) days shall constitute a termination of EL's right to use such Street Light.
- 5.6 Standard of Performance; Risk. EL shall, at its own sole risk and expense, install and maintain Communications Equipment on Street Lights as authorized under this Agreement and Construction Permits issued by the City, and shall do so in a professional and workmanlike manner, in accordance with industry standards, and in accordance with all applicable federal, state, and local laws, ordinances and regulations. EL shall at all times maintain the Communications Equipment in a safe condition, and shall use and exercise due care, caution, skill and expertise in performing all work authorized under this Agreement and any Construction Permit issued by the City, and shall take all reasonable steps to safeguard work areas, including, without limitation, Street Lights, streets and sidewalks, City property and facilities, and property and facilities owned or occupied by others. The City shall exercise reasonable efforts, subject to the terms of this Agreement and the requirements of applicable provisions of The Philadelphia Code, to facilitate the issuance of appropriate permits and licenses to EL and/or its Subcontractor(s) for the installation and maintenance of the Communications Equipment pursuant to this Agreement.
- 5.7 Electricity. Nothing in this Agreement shall in any way obligate PAID or the City to pay the cost of electricity required by any Communications Equipment installed on Street Lights or in any other City site or facility.
- 5.8 Emergency Contact Information. EL and the City shall provide each other with current 24 hour, 7 days-a-week telephone and other contact information to facilitate prompt communications in emergencies. In the event that EL or the City reports an emergency to the other party, then the other party shall promptly respond and perform any work necessary to repair the emergency condition, to the extent required by its obligations hereunder, at no cost to the reporting party, unless the reporting party caused the emergency condition, or the reporting party is obligated to pay for such service by this Agreement or by applicable contracts between EL and the City.
- 5.9 Information Tags. EL will attach to each item of Communications Equipment installed on a Street Light an information tag that has the following information: Name and mailing address of the owner of the equipment; a telephone number that is staffed 24 hours a day, 7 days a week; the owner's facsimile number; and an email address where the owner's operating personnel can be reached.
- 5.10 Hazardous Materials. Unless the Streets Commissioner directs otherwise, EL shall provide written notice to the Commissioner of any material in its Communications Equipment which is defined or identified as hazardous, toxic, dangerous, or as creating a potential risk to

human health or the environment, in any applicable federal, state, or local environmental law or regulation, before the material is brought onto any Street Light or any City property. For any such material, EL shall provide in its notice information sufficient to identify the material and enable the City to assess the hazard presented. EL shall undertake, at its cost, any and all investigatory, preventive, and remedial action (including emergency response, removal, containment and other remedial action) which may be required with respect to such material by any applicable federal, state, or local environmental laws or regulations, and/or by the orders of any governmental authority having jurisdiction under such laws or regulations. Compliance with any such order concerning the material which is directed to the City shall nonetheless be the responsibility of EL, at EL's cost.

5.11 **Notice to Residents.** If the Streets Commissioner reasonably determines that EL's installation of Communications Equipment on Street Lights in one or more blocks of the City will disrupt pedestrian or vehicular traffic, or adversely affect residents or businesses, then the Commissioner may require that EL provide notice to residents, and businesses in those blocks before commencing construction.

5.12 **Compliance with Regulations.** The Communications Equipment and all other work authorized and performed by EL under this Agreement shall be placed and maintained in accordance with the requirements and specifications of all applicable rules and regulations of the Federal Communications Commission, Pennsylvania Public Utilities Commission, the most current editions of the National Electrical Code, the National Electrical Safety Code, the rules and regulations of the Occupational Safety and Health Act (OSHA), and the rules and regulations of any governing authority having jurisdiction over the work to be performed. In the event such codes or authorities have differing requirements, the more stringent requirement(s) shall apply.

6 **Interruption To Service And Damage To Property.**

6.1 **Interruptions.** No Communications Equipment or installation thereof may in any way interfere with or degrade or interrupt the operation of any Street Light. If such interference, interruption, or degradation occurs, EL shall restore the Street Light and Street Light service within twenty-four (24) hours of notice by the Streets Commissioner. If EL fails to so correct, the Streets Department may take corrective action, upon notice to EL, and EL shall be liable for the reasonable costs incurred by the City therefor. Disruptions to Street Light operation caused by the attachment of electrical supply cables for Communications Equipment to the photocells on Street Lights, in accordance with the installation method set forth in Exhibit A, shall not be subject to this Section 6.1 provided the disruptions are necessary to install the Communications Equipment.

6.2 **Damage to Property.** EL, PAID and the City shall each assume responsibility for any loss from damage caused by that Party to the property of the other. Each party shall make an immediate report of the occurrence of any such damage to the other and, subject to Section 9.4, *Limitation of Liability*, shall on demand and receipt and review of documentation of the costs incurred, reimburse the other for its out of pocket cost incurred in making repairs or replacing damaged property to the extent the damages were caused by the negligence or wrongful actions of that party.

6.3 Nothing in this Section 6 shall (i) limit, alter, or waive EL's obligations under Section 9, *Indemnification, Independent; Contractor; Limitation of Liability*, or (ii) be construed as a waiver of those defenses, immunities, and limitations on damages available to the City and PAID pursuant to the Pennsylvania Political Subdivision Tort Claims Act, Act of October 5, 1980, P.L. 693, No. 142, (42 Pa.C.S.A. § 8541 et. seq.), or the Commonwealth Agency Law, 42 Pa. C.S.A. § 8521 et seq..

6.4 **Parties Bear Their Own Costs.** Except as expressly provided otherwise in this Agreement, EL and the City shall each pay the cost of the installation and maintenance of its own facilities. Nothing in this Agreement shall be construed to compel the City to retain in place or to maintain any Street Light for a period longer than the City requires for its street lighting purposes, provided, however, that if the City wishes to terminate its maintenance of a Street Light, the City shall cooperate reasonably with EL in obtaining access to alternative facilities in a manner that minimizes service interruptions and costs.

7 **Compensation.**

7.1 In consideration for the right to use Street Lights as provided in this Agreement, EL shall pay to PAID for the account of the City, during the Initial Term and any Renewal Terms, the money payments and provide to the City the other compensation set forth below. The money payments provided in Sections 7.1.2-7.1.3 below are the same money payments as those described in Section 1.1-1.5 of the Network Agreement.

7.1.1 **Prepayment of Street Light Use Fees.** EL shall pay to PAID for the account of the City the following non-refundable use fees for the Street Lights used by EL in operating the Wireless Network during the initial 10 year term of this Agreement:

7.1.1.1 Within twenty (20) days after the execution of this Agreement and satisfaction of the "First Payment Conditions," as provided in Section 4.1 of the Network Agreement, EL shall pay to PAID for the account of the City Two Hundred and Fifty Thousand Dollars (\$250,000).

7.1.1.2 Within twenty (20) days after Proof of Concept Acceptance, EarthLink shall pay to PAID for the account of the City Seven Hundred and Fifty Thousand Dollars (\$750,000).

7.1.1.3 One (1) year after Proof of Concept Acceptance, EarthLink shall pay to PAID for the account of the City One Million Dollars (\$1,000,000).

7.1.2 **Monthly Street Light Use Fee.**

In addition to the Street Light use fees provided in Section 7.1.1, EL shall pay to PAID for the account of the City a use fee of Two Dollars (\$2) per month for each Street Light on which Communications Equipment of EL is installed as of the last day of the preceding month ("Monthly Use Fee"). Commencing with the month after Proof of Concept Acceptance, EL shall owe payments of the Monthly Use Fee in arrears for each

previous month, and shall make such payments within sixty (60) days of the date that the City sends an invoice to EL for the fees. The City may, in the Streets Commissioner's discretion, invoice for the Monthly Use Fee monthly, quarterly, semi-annually, or annually.

7.1.3 City Wireless Accounts.

7.1.3.1 Wi-Fi Accounts.

EL shall furnish the number of Muni Wi-Fi product accounts to the City, at the City's sole option and for municipal purposes, for the prices provided in Sections 7.1.3.1 (a) – (c). The Muni Wi-Fi product accounts shall provide Base Service as set forth in Exhibits A and I of the Network Agreement. In the City's sole discretion, the City may package Core ISP Services, including but not limited to email, software, support, personal start pages, web hosting, newsgroups, VPN, and other Core ISP Services selected by the City with the Muni Wi-Fi product at the City's cost. The City will be responsible for the cost of CPE and installation services, and may, in its sole discretion, itself provide and/or charge its subscribers for CPE and installation services. Tier 0, 1, 2 and 3 subscriber support for the Muni Wi-Fi product accounts will be provided by the City or by WP, and Tier 3 network support will be provided by EL, all as set forth in Exhibit M of the Network Agreement. EL shall provide the accounts and EL Tier 3 support directly to the City, and shall bill account charges, if any, and the cost of EL-provided support, if any, directly to the City. If EL discontinues the Muni Wi-Fi product and replaces it with a product of the same or higher transmission rate, as described in Exhibit I, Section 16 of the Network Agreement, EL shall provide accounts for such replacement product to the City in accordance with the terms of this Section 7.1.3. Any Muni Wi-Fi product accounts made available to the City will appear in EL's operational support systems as City wholesale accounts.

(a) 1250 accounts will be furnished at no cost to the City.

(b) The next 1750 accounts will be furnished at a price that does not exceed Four Dollars (\$4) per account per month, determined as follows: If the City and/or WP negotiate savings from PECO on electricity to power the Communications Equipment that results in the electricity cost falling below Four Hundred Thousand Dollars (\$400,000) per year, then the City will pay a price per account calculated according to the following formula:

$$\text{Monthly Fee per Account} = (0.5 \times \text{Annual Savings (i.e. the difference between \$400,000 and the lower price negotiated)}) / (12 \times 1750)$$

(c) The City may purchase accounts in excess of Three Thousand (3,000) at the lowest wholesale rate charged to any wholesale customer on the network, without regard to the number of accounts the City purchases (i.e. the City will receive the highest wholesale volume discount available to any wholesale customer on the network, regardless of number of accounts it purchases).

Accounts purchased under this subsection (c):

- (1) Shall be utilized for municipal government activities and purposes, and shall not be used for non-City activities, such as recreational use;
- (2) Shall fall under a wholesale account umbrella which shall be managed by a single designated point of contact within the City;
- (3) Shall access the system through City specific non-broadcast Service Set Identifiers (SSIDs);
- (4) Shall be routed by EL proxy RADIUS server to a designated City RADIUS server for authentication;
- (5) Shall be provisioned only to employees of the City or to the employees of City-Related Agencies as defined in Section 17-1401(9) of The Philadelphia Code;
- (6) Shall be accounts associated with the City's primary domain, phila.gov, or such other domains that as a matter of regular practice are managed by the City's IT departments;
- (7) Shall receive Tier 3 Network Operations Center (NOC) support via a single interface from the City's Tier 3 NOC to EarthLink's Tier 3 NOC support center;
- (8) Shall be billed on a single invoice each month;
- (9) Shall not be resold, except to City-Related Agencies as defined in Section 17-1401(9) of The Philadelphia Code;

7.1.3.2 **T1 Alternative Accounts.** EL shall furnish up to Seven Hundred (700) T1 alternative product ("Muni T1") accounts to the City, at the City's sole option and for the price of not more than One Hundred Dollars (\$100) per month per account, plus a one-time, non-recurring fee for CPE and installation (which may be waived by EL for a multiyear agreement commitment) of not more than Two Hundred and Fifty Dollars (\$250) per account. The Muni T1 alternative product shall provide point-to-multipoint fixed wireless data transmission and Internet access to municipal buildings and municipal government locations with a minimum 1.5 Mbps downstream / 1.5 Mbps upstream data transmission rate, and dynamic and static IP addresses (as requested by the City). EL shall exercise its best efforts to provide such data transmission rate(s). Muni T1 accounts shall be supported in the same manner as the Open Access ("OA") Wi-Fi Broadband Products, with Tier 0, 1, 2 and 3 subscriber support provided by the City or by WP, and Tier 3 network support provided by EL, all as set forth in Exhibit M of the Network Agreement. EL shall provide the accounts and deliver installation and CPE directly to the City, and shall bill account charges and the cost of EL provided CPE and installation services directly to the City.

- 7.1.3.3 Accounts at City Option. All Wi-Fi Broadband Product accounts and T1 Alternative Product accounts provided in this Section 7.1.3 will be furnished by EL to the City at the City's sole option, which option may be exercised by the City, in its sole discretion, at any time during the Initial Term of this Agreement and any Renewal Terms. EL shall make the accounts available to the City after Final Acceptance of the Wireless Network in accordance with the terms and conditions of this Section within thirty (30) days of the City's written request, or such lesser or greater time as EL and the City may agree to in writing. Neither PAID nor the City shall be obligated at any time to receive, use, or purchase any minimum number of wireless accounts.
- 7.1.3.4 If EL's provision of WiFi Retail Product accounts or T1 Alternative Product accounts under this Section 7.1.3 results in a sales tax charge to EL, the City will pay the amount of the sales tax to EL for remittance to appropriate tax authorities.
- 7.1.4 EL acknowledges that PAID has no economic interest in the payments due from EL under this Section 7.1.
- 7.2 Overdue Payments. If EL fails to pay any undisputed amounts payable under this Agreement within the time period provided for the payment in this Section 7, such unpaid amount shall bear interest thereafter until paid at the lower rate of eight percent (8%) per annum or, the maximum rate permitted by applicable law. This late payment interest has been agreed upon by PAID, the City and EL, after negotiation, as a reasonable estimate of the additional administrative costs and detriment that PAID and the City will incur as a result of any such failure by EL, the actual costs thereof being extremely difficult if not impossible to determine. The late payment interest constitutes liquidated damages to compensate PAID and the City for its damages resulting from such failure to pay and shall be paid to PAID, for the account of the City, together with such unpaid amount. Payment of such interest shall not excuse or cure any default by EL.
- 7.3 Audit. At all times during the Initial Term and any Renewal Term(s) of this Agreement, and for three (3) years after expiration or termination of the Agreement, EL shall keep and maintain all books, records, correspondence and documents of EL relating to the payment of the compensation provided in this Section 7, and on fourteen (14) days written notice shall make them available for audit, inspection and examination in Philadelphia (or another location if agreed upon by both parties in writing) by the Controller of the City of Philadelphia, PAID, and/or the Streets Commissioner or their designees. If such audit reveals a deficiency in payments due and owing under this Section 7, EL shall pay the deficiency within fourteen (14) days following written notice, together with interest thereon at a rate of ten percent (10%) per annum for each year in which the deficiency continued; provided, that the maximum amount of such interest shall be the greater of (i) ten percent (10%) per annum for each year the deficiency continued up to a maximum of four (4) years or (ii) ten per cent (10%) of the total amount of the deficiency, and provided further that such interest shall be in lieu of the interest required pursuant to subsection 7.2. If the amount of such deficiency is greater than ten percent (10%), then EL shall also pay the costs incurred by the City and/or PAID for the audit. If any audit such reveals an overpayment by EL, EL shall be entitled to a credit against the next payments due and

owing to the City under this Section 7 in the amount of the overpayment. Materials provided to the City under this Section 7.3 shall be subject to Section 13, *Confidentiality*.

- 7.4 Disposition of Payments on Dissolution or Bankruptcy of WP. In the event WP is dissolved, or if a Bankruptcy Event (as defined below) occurs with respect to WP, or WP otherwise ceases to operate, PAID shall have the right (but not the obligation), at its sole option, to receive, for the account of the City, all money payments and other consideration that EL is obligated to pay directly to WP under this Section 7 and under the Network Agreement, to the extent permitted by applicable law, or to designate an entity, including the City, to receive, for the account of the City, such money payments and other consideration. In the event PAID exercises the foregoing right, PAID will, to the extent permitted by law, assume the Network Agreement and/or the obligations of WP under the Network Agreement or cause its designee, if applicable, to assume the Network Agreement and WP's obligations under it. PAID further agrees that if it exercises such right, it or its designee, if applicable, will use the money payments and other consideration paid to it or its designee by EL to further the WP Mission. PAID may exercise the rights provided in this Section 7.4 by delivering written notice to EL, together with reasonable evidence that WP has been dissolved or has ceased to operate. If PAID designates another entity pursuant to this Section, PAID shall have no liability hereunder or with respect to the performance by such entity.

“Bankruptcy Event” means that WP (i) applies for or consents to the appointment of a receiver, trustee, liquidator or custodian or the like of itself or of its property, (ii) admits in writing its inability to pay its debts generally as they become due, (iii) makes a general assignment for the benefit of creditors, (iv) is adjudicated a bankrupt or insolvent, (v) commences a voluntary case under the United States Bankruptcy Code, or files a voluntary petition or answer seeking reorganization, an arrangement with creditors or an order for relief, or seeking to take advantage of any insolvency law or file an answer admitting the material allegations of a petition filed against it in any bankruptcy, reorganization, or insolvency proceeding, or action shall be taken by it for the purpose of effecting any of the foregoing, or (vi) has instituted against it, without its application, approval or consent, a proceeding in any court of competent jurisdiction, under any law relating to bankruptcy, insolvency, reorganization or relief of debtors, seeking in respect of WP an order for relief or an adjudication in bankruptcy, reorganization, dissolution, winding up, liquidation, a composition or arrangement with creditors, a readjustment of debts, the appointment of a trustee, receiver, liquidator or custodian or the like of WP or of all or any substantial part of its assets, or other like relief in respect thereof under any bankruptcy or insolvency law, and, if such proceeding is being contested by WP in good faith, the same shall (A) result in the entry of an order for relief or any such adjudication or appointment or (B) remain unvacated, undismissed and undischarged for a period of 90 days.

- 7.5 The payments provided in Section 7.1 shall be deemed to include payment of fees related to the issuance of Construction Permits (but not to include the costs of construction inspections provided in Section 5.1.1.2); provided, that the Streets Commissioner may charge a permit fee of up to Eighteen Dollars (\$18) per Street Light for Construction Permits issued to EL for any Street Light in excess of four thousand (4,000).

8 Insurance; Removal Security.

8.1 Insurance.

8.1.1 General Requirements.

EL shall, at its sole cost and expense, procure and maintain in full force and effect, covering risks associated with the construction, installation, placement, operation, maintenance, use, renewal, replacement, relocation, repair and removal of Communications Equipment placed or to be placed on Street Lights or otherwise on City property or in the Right-of-Way, the types and minimum limits of liability insurance specified below. All insurance shall be procured from insurers (i) licensed and authorized to write insurance in Pennsylvania, (ii) acceptable to the City's Risk Manager and to PAID, which acceptance will not be unreasonably withheld or delayed, and (iii) with an A.M. Best rating of A-VIII or higher, unless agreed otherwise in writing by the City's Risk Manager and PAID. All insurance required herein shall be written on an "occurrence" basis, or if any policy is written on a claims made basis, the retroactive date may not be advanced beyond the date of this agreement and coverage shall be maintained in full force and effect for two (2) years after termination of this Agreement, which coverage may be in the form of tail coverage or extended reporting period coverage if agreed by the parties. The certificate of insurance shall provide for at least thirty (30) days prior written notice to be given to the City Department of Streets (7th Floor, Municipal Services Building, Philadelphia, PA 19102), the City's Risk Manager (One Parkway, 14th Floor, 1515 Arch Street, Philadelphia, PA 19102-1595), the City's Law Department (One Parkway, 17th Floor, 1515 Arch Street, Philadelphia, PA 19102-1595); and to PAID and the Philadelphia Industrial Development Corporation ("PIDC") (Philadelphia Authority for Industrial Development, 2600 Centre Square West, 1500 Market Street, Philadelphia, PA 19102-2126, Attn: Risk Magement – Wireless Phl) in the event coverage is cancelled or non-renewed. In the event coverage is materially changed, EL or its insurer shall provide at least thirty (30) days prior written notice to the City and to PAID at the above addresses.

8.1.2 The City of Philadelphia, PAID and PIDC, and their respective officers, directors, and employees, shall be named as endorsed named insureds on each insurance policy required by this Agreement, except policies for Workers' Compensation, and on any insurance EL requires of any person, agent, Subcontractor, or employee engaged or employed in, about or upon the work by, at the instance of, or with the approval or consent of EL, as respects the acts, omissions, operations and activities of, or on behalf of, the named insured, in regard to products supplied, or work or services performed for, or under an agreement with, PAID and/or the City of Philadelphia.

8.1.3 A certificate of insurance shall be provided to PAID and to the City's Risk Manager, as set forth below, that evidences the required coverages. The certificate of insurance shall state that such coverages will be primary to any coverage available to them and will be noncontributory.

8.2 Types and Minimum Limits of Insurance. EL shall furnish the following types and minimum limits of insurance:

8.2.1 Workers' Compensation and Employers' Liability insurance

- (1) Workers' Compensation: To meet Pennsylvania statutory requirements
- (2) Employers' Liability: \$500,000 each Accident - Bodily Injury by Accident; \$500,000 Each Employee - Bodily Injury by Disease; and \$500,000 Policy Limit Bodily Injury by Disease

8.2.2 Commercial General Liability insurance

- (1) Limit of liability: The Commercial General Liability Insurance Policy in an amount not less than \$5,000,000 per occurrence, Twenty Million Dollars (\$20,000,000) annual aggregate, written on an occurrence form, provided this coverage may be maintained by EL combining primary and excess policies to meet these requirements.
- (2) Types of insurance: Applicable dollar limit, as set forth in (1), per occurrence combined single limit for bodily injury (including death) and property damage liability; applicable dollar limit, as set forth in (1), for personal and advertising injury; applicable dollar limit, as set forth in (1), general aggregate; and applicable dollar limit, as set forth in (1), for products and completed operations
- (3) Coverage: Premises operations; blanket contractual liability; personal injury liability (employee exclusion deleted); products and completed operations; independent contractors; employees and volunteers as additional insureds; cross liability; broad form property damage (including completed operations); and explosion, collapse, underground hazards (XCU)

8.2.3 Commercial Automobile liability insurance

- (1) Limit of liability: \$5,000,000 per occurrence combined single limit for bodily injury (including death) and property damage liability, provided this coverage may be maintained by EL combining primary and excess policies to meet these requirements
- (2) Coverage: Owned, non-owned and hired vehicles

8.2.4 The City's Risk Manager, with the consent of PAID, is hereby authorized to reduce the requirements set forth herein in the event he determines that such reduction is in Philadelphia's best interest.

8.3 Evidence of Insurance Coverage

Prior to commencing any work under an agreement with WP or accessing or using any Street Light, EL shall deliver to PAID and the City of Philadelphia certificates of insurance evidencing the required coverages and endorsed named insureds, which must specifically reference in the description sections of the certificates such agreement between WP and EL and this Street Light Use Agreement. Original certificates of insurance must be submitted to PAID at the following address:

Philadelphia Authority for Industrial Development
2600 Centre Square West
1500 Market Street
Philadelphia, PA 19102-2126
Attn: Risk Management – Wireless Phl

and to the City's Risk Manager at the following address:

City of Philadelphia
Finance Department
Division of Risk Management
1515 Arch Street, 14th Floor
Philadelphia, PA 19102-1579
(Fax No.: 215-686-1705).

PAID and the City each reserves the right to inspect on the site of EL copies of policies of all insurance required in this Section 8, or alternatively, at the option of the City or PAID, to require EL to demand that its authorized insurance representatives furnish written responses to all inquiries made by the City or PAID pertaining to the insurance required under the Agreement at any time upon ten (10) days written notice to such insurance representatives. Also, in the event that (i) a claim is filed against PAID, PIDC, or the City, or their officers, employees, agents, or representatives, for which PAID, PIDC, or the City believes, in good faith, there may be coverage under an insurance policy required by this Agreement, and (ii) PAID, PIDC, or the City has tendered such claim to the insurer that issued such policy, and (iii) such insurer has not agreed, within ninety (90) days, to cover such claim, including defense and indemnity, without reservation, then the City or PAID or PIDC each has the right to demand of EL, and to receive within thirty (30) days, a copy of such insurance policy.

8.4 Contractors.

EL shall require that its contractors procure and maintain, or cause to be procured and maintained, throughout the entire period of construction, operation and maintenance of Communications Equipment on any Street Light, the types of insurance, limits of insurance, and designation of additional insureds which are required of EL under this Section 8.

8.5 Removal Security. Prior to Proof of Concept Acceptance, EL shall furnish to the City and PAID removal security in the form of a letter of credit, in the amount of Five Hundred Thousand Dollars (\$500,000), to pay the City's costs of removing the Communications

Equipment from Street Lights in the event EL fails to remove the Communications Equipment when required to do so under this Agreement. EL shall deliver to the City and PAID a letter of credit issued by Bank of America or another national bank approved by the City and PAID, in the form attached hereto as Exhibit C, with changes as approved by the City and PAID.

- 8.5.1 The letter of credit, or replacement letters of credit delivered to the City at least ten (10) days before the expiration of the previous letter of credit, shall be effective throughout the Initial Term and any Renewal Terms and for two years after the date of expiration or termination of the last such Term; provided, that the letter of credit shall be returned to EL for cancellation prior to such time if, but only if, (i) the City determines in its reasonable judgment that all Communications Equipment has been removed from Street Lights, and (ii) the City determines in its reasonable judgment that all storage obligations of the City regarding removed Communications Equipment that are provided in this Section 8.5.1 and elsewhere in the Agreement have also terminated.
- 8.5.2 The City shall be entitled to draw on the letter of credit five (5) business days following delivery of a written certification by the Streets Commissioner of the City to the issuing bank and to EL certifying that EL has not met its obligation to remove Communications Equipment from the Street Lights pursuant to this Agreement within the time required under the Agreement, and certifying the dollar amount required by the City to remove the Communications Equipment, together with reasonable documentation. The letter of credit disbursement shall be limited to the amount of the removal expenses stated and reasonably documented by the Streets Department. After a draw request is paid by the issuer of the letter of credit in that amount, then the balance remaining on the letter of credit shall be available for further draws by the City as may be required to remove other Communications Equipment not removed by EL pursuant to the Agreement. In the event the City's actual cost of removal is less than the amount stated in the Streets Commissioner's certification, or in the event the City does not remove the Communications Equipment within eighteen (18) months of the disbursement, then the City shall promptly refund the amount of such difference to the issuer of the letter of credit, which will credit the refund to the amount that can be drawn on the letter of credit.
- 8.5.3 Except as otherwise expressly stated in the letter of credit, the credit provided therein is subject to the International Standby Practices (ISP98), International Chamber of Commerce Publication No. 590 and, to the extent not in consistent therewith, the laws of the State of New York.

9 Indemnification; Independent Contractor; Limitation of Liability.

- 9.1 Independent Contractor. EL and its Subcontractors are each an independent contractor and shall not in any way or for any purpose be deemed or intended to be an employee or agent of PAID or the City. Neither EL nor its Subcontractor(s) nor their respective employees, directors, agents or Subcontractors shall in any way represent that they are acting as employees, officials or agents of PAID or the City.

9.2 Indemnification. EL shall indemnify, defend and hold harmless the City, PAID and PIDC and their respective officers, employees, contractors, consultants, members and agents, from and against any and all losses, costs (including, but not limited to, litigation and settlement costs and counsel fees), claims, suits, actions, damages, liabilities and expenses, to the extent caused by or resulting from EL's act or omission or negligence or fault, or the act or omission or negligence or fault of EL's agents, Subcontractors, suppliers, or employees in connection with this Agreement, use of the Street Lights by EL or its agents, Subcontractors, suppliers, or employees, and the installation, repair, replacement, operation, maintenance, and/or use of Communications Equipment on Street Lights, including, but not limited to, those in connection with loss of life, bodily injury, personal injury, damage to property, contamination or adverse effects on the environment, intentional acts, failure to pay such Subcontractors or suppliers.

9.3 Indemnification for Infringement of Proprietary Rights.

9.3.1 EL will indemnify PAID, PIDC, the City, and their respective officers, employees, contractors, consultants, members and agents, but not any customers or third parties ("Indemnitees"), from losses, costs and damages and defend any suit or proceeding brought against the Indemnitees to the extent that the suit or proceeding is based on a claim that the Network Operations constitute infringement of any United States patent, mask work, trade secret or copyright and EL will pay, or EL will cause the supplier of the infringing Network Operations to pay, all damages awarded by final judgment (from which no appeal may be taken) against the Indemnitees, but not any customers or third parties, holding that the Network Operations do so infringe, on condition that EL (i) is promptly informed and furnished a copy of each communication, notice or other action relating to the alleged infringement, (ii) is given authority, information and assistance necessary to defend or settle the suit or proceeding in a manner as EL may determine and (iii) is given sole control of the defense (including the right to select counsel and to require and allow the supplier of the infringing Network Operations to pay damages and defend as provided herein), and the sole right to compromise and settle the suit or proceeding; provided, however, that no such compromise or settlement shall impose any liability or burden on the City or PAID without their consent. If any Network Operations are held to infringe any valid United States patent, mask work, trade secret or copyright as set forth above, and an injunction from a court of competent jurisdiction permanently prohibits the use of the same in the Wireless Network, or if EL believes infringement is likely, then EL will (a) procure the right to use the Network Operations in the Wireless Network free of any liability for infringement, (b) replace or modify the Network Operations in the Wireless Network with a non-infringing substitute otherwise complying substantially with the specifications for the Wireless Network; or (c) comply with the subsequent sentence. In the event that (i) a court of competent jurisdiction determines that the Network Operations infringe the above-defined rights of another party, (ii) all right of appeal or stay is exhausted as to such order, and (iii) EL is unable to replace or modify such infringing Network Operations in the Wireless Network or otherwise procure the right to continue using the Network Operations in the Wireless Network then EL will be entitled to remove the infringing Network Operations from the Wireless Network and obtain substitutes that will result in the Wireless Network performing substantially as required in this Agreement. "Network Operations" means (i) the Wireless

Network or any portion thereof (ii) products and services provided directly by EL, parents and subsidiaries of EL and companies commonly owned with EL (“Affiliates”) or Subcontractors through the Wireless Network, and (iii) operation and design (including attaching devices to Street Lights) of the Wireless Network.

9.3.2 **Limitation of Intellectual Property Indemnification.** In no event will EL or its suppliers be liable for an infringement that: (i) would not have existed but for the use of products or services in the Wireless Network that were not provided by EL or its Affiliates or Subcontractors; or (ii) would not have existed but for modification of, or additions to, the Network Operations by the City or its contractors or agents. Prior to a final determination that the infringement arose from clauses (i) or (ii) in the preceding sentence, EL shall remain fully responsible, at its expense, for the defense and indemnification of any infringement claim in accordance with this Section: provided, that if it is finally determined that the infringement arose from clauses (i) or (ii) in the preceding sentences, then PAID and/or the City will reimburse EL for its reasonable expenses (including reasonable litigation costs and attorneys fees) incurred therein.

9.3.3 **Exclusive Liability for Infringement** *THE FOREGOING CONTAINS THE SOLE AND EXCLUSIVE LIABILITY FOR EL’S AND ITS SUPPLIERS’ INDEMNITY AGAINST INFRINGEMENT IN THIS SECTION 9.3, WHETHER DIRECT OR CONTRIBUTORY, AND IS IN LIEU OF ALL WARRANTIES, EXPRESS, IMPLIED OR STATUTORY IN REGARD THERETO, INCLUDING, WITHOUT LIMITATION, THE WARRANTY AGAINST INFRINGEMENT SPECIFIED IN THE UNIFORM COMMERCIAL CODE.*

9.4 **Limitation of Liability.**

9.4.1 Subject to the exceptions provided in Section 9.4.2, EL’s liability to the City and/or PAID for damages in connection with this Agreement shall not exceed the total amount of One Million Dollars (\$1,000,000), and the liability of the City and PAID to EL for damages in connection with this Agreement shall not exceed the total amount of One Million Dollars (\$1,000,000).

9.4.2 Section 9.4.1 and the limitations of liability provided therein shall not apply to damages relating to or arising from loss of life, bodily injury, personal injury, damage to property, contamination or adverse effects on the environment, or EL’s liability for damages pursuant to Section 9.3, *Indemnification for Infringement of Proprietary Rights*.

9.4.3 Notwithstanding any provision or obligation to the contrary set forth in this Agreement or in any related document, no provision herein shall be construed so as to give rise to any pecuniary liability of PAID or its members, directors, officers, employees, agents, subcontractors, or representatives for a charge upon or claim against the general credit or assets of PAID or of such members, directors, officers, employees, agents, subcontractors, or representatives except to the extent of PAID’s economic interest in this Agreement as set forth in the next sentence. Any pecuniary liability of PAID in connection herewith, under any theory of law, including contract or tort, whether for damages for breach or for any other reason whatsoever, is expressly and exclusively limited to PAID’s economic interest in this Agreement and the lien of any judgment shall be expressly restricted thereto.

9.5 Statutory Immunities and Defenses. Nothing in this Section 9 shall waive or amend any defense or immunity that the City or PAID or their officers, agents or employees may have under the Pennsylvania Political Subdivision Tort Claims Act, 42 Pa.C.S.A. section 8541, et seq., or the Commonwealth Agency Law, 42 Pa. C.S.A. § 8521 et seq.

9.6 No damages for Delay. EL shall be entitled to a reasonable extension of the time for performing any action required of EL under this Agreement if its failure to perform such action is caused by City delay; provided, however, that no such extension shall be granted unless a written request, setting forth in reasonable detail the grounds therefor, is received by the City within ten (10) calendar days following the events giving rise to such alleged delay, or at least two (2) days prior to the expiration of the time for performance if it is less than ten (10) days. EL's sole and exclusive remedy for costs or damages arising from any delay to its performance of actions required under this Agreement or under the Network Agreement that is caused by any act or omission of the City (including its officers, employees, contractors and agents) shall be an extension of the time of performance, as provided in this Section 9.6 (and in the Network Agreement for actions required under the Network Agreement). In no event shall EL be entitled to monetary payment or compensation of any kind from PAID or the City for any costs or damages incurred as a result of delay in its performance of any obligation of EL, PAID or the City, or to WP, EL's contractors, or any other party, that is caused by any act or omission of the City or PAID (including their officers, employees, contractors, members and agents), including, without limitation, such delay to the construction of the Wireless Network, and/or delay in the performance of any other obligation of EL under the Network Agreement or under this Agreement.

10 Dispute Escalation.

10.1 Any dispute between EL and the City or PAID which arises during the Initial Term or any Renewal Term of this Agreement and which the parties to the dispute cannot then resolve, shall be subject to the following dispute resolution procedure.

10.2 The parties shall attempt to resolve any controversy claim, problem or dispute (a "Dispute") arising out of, or related to, this Agreement through good faith consultation in the ordinary course of business. In the event that the Dispute is not resolved by the project managers of the parties to the Dispute, any party to the Dispute may upon written notice to the other party or parties to the Dispute request that the matter be referred to senior management officials within each respective organization with express authority to resolve the Dispute ("Request for Internal Resolution"). A written Request for Internal Resolution shall be given by any party to the Dispute within thirty (30) calendar days of the party's knowledge of the unresolved Dispute. Senior management officials shall meet or confer at least once in good faith, to negotiate a mutually acceptable resolution within thirty (30) days of the Request for Internal Resolution ("Dispute Resolution Period"). For the purposes of this paragraph, the designated project manager or senior management official for PAID shall be Samuel V. Rhoads, Senior Vice President of PIDC; for the City, shall be the Managing Director of the City or his designee; and for EL, shall be the President of EL Municipal Networks. The project managers and senior management may be changed by

notice given by the party changing its personnel. EL acknowledges that any disputes are likely to be between it and the City and that PAID is not intended to be a necessary participant in any such dispute.

10.3 Project managers and senior management officials are required to meet only once but may mutually agree to meet more than once if it appears that further meetings may successfully resolve the Dispute.

10.4 The provisions of this Section 10 shall not apply to a Termination Default as set forth in Section 12, *Termination and Default*, though the executives of each party shall make themselves available to each other upon request during the cure periods set forth therein.

11 Term, Renewal, Expiration and Removal.

11.1 Initial Term. This Agreement shall become effective on the Effective Date and unless sooner terminated in accordance with the terms and conditions hereof, shall continue in effect for ten (10) years after the date on which the Proof of Concept Trial is accepted and approved by the City and WP (the "Initial Term").

11.2 Renewal. Upon expiration of the Initial Term, the Agreement may be renewed for up to two (2) successive five (5) year periods of time ("Renewal Term(s)") at the discretion of PAID, at the direction of the City, and with the agreement of EL, provided that EL furnishes to PAID and the City, for each Renewal Term, at least eighteen (18) months prior written notice of its intent to renew. If PAID elects not to renew the Agreement, it will so notify EL at least twelve (12) months prior to the expiration of the then current term.

11.3 Expiration and Removal. Upon expiration of the Initial Term and all Renewal Terms entered into pursuant to Section 11.2, EL shall, at its own expense, within twelve (12) months of such expiration, remove the Communications Equipment from the Street Lights and restore all Street Lights to at least the condition (taking into account normal wear and tear) they were in prior to the installation of the Communications Equipment. If EL fails to remove the Communications Equipment from the Street Light Poles within twelve (12) months, the City shall have the right, but not the obligation, to remove any of the Communications Equipment so remaining, and EL shall reimburse the City for its costs incurred in connection with removing the Communications Equipment; provided, that if EL does not so reimburse the City within thirty (30) days following the City's written notice of its removal costs, the City may draw on the removal security provided in Section 8.5, *Removal Security*; and provided further that if sufficient funds remain of such removal security to pay storage costs after the payment of all costs incurred by the City to remove the Communications Equipment, the City will store the removed Communications Equipment in a location of the City's choice and give EL written notice that it has done so. If EL does not remove the Communications Equipment from the City's storage location within sixty (60) days following such notice, the City may dispose of the stored Communications Equipment in any manner that it chooses, without cost or liability to the City. In no event shall the City be liable for theft or loss of or damage to the Communications Equipment, of any kind or nature whatsoever, that occurs during removal

from the Street Lights, or while the Communications Equipment is in storage, whether or not such theft, loss, or damage is the result of any act or omission of the City.

12 Default and Termination.

12.1 Termination for Termination Default. PAID, at the direction of the City, shall have the right, but shall not be obligated to, terminate this Agreement and EL's authorization to use Street Lights provided in the Agreement in the event that one or more of the defaults set forth in Sections 12.1.1-12.1.3 ("Termination Default(s)") has occurred and continued uncured until after the end of all applicable cure periods set forth therein. Notwithstanding anything to the contrary in this Agreement, PAID shall not, however, terminate the Agreement and EL's authorization to use Street Lights provided in the Agreement unless one or more of the Termination Defaults has occurred and continued uncured until after the end of all applicable cure periods set forth therein; and any other default or failure of EL to comply with this Agreement shall not permit such termination. In the event of conflict with any other provision of this Agreement relating to termination of the Agreement and such authorization to use Street Lights, this provision shall govern; provided, however, that nothing in this Section 12.1 is intended to or shall limit, alter, or waive any remedy provided in the Agreement other than termination of the Agreement and EL's authorization to use Street lights, including, without limitation, the termination and other remedies set forth in Section 12.2, *Remedies for Noncompliance*, and the remedies provided elsewhere in the Agreement.

12.1.1 Failure to Accomplish System Implementation and Deployment. It shall be a Termination Default by EL if deployment of the Wireless Network in substantially all of the Coverage Area (as described in the Design Control Documents) is not accomplished within twelve (12) months after the date set forth on the Schedule for completion of the implementation and deployment of the network that is provided for in the Network Agreement; provided, that such time will be extended by any delays caused by WP, PAID, the City, by providers of electricity to the Wireless Network, providers of telecommunications service to the Network other than EL, by third parties (other than Subcontractors of EL) that are not under the control of EL, or by a Force Majeure Event. Provided that Communications Equipment to be installed on Street Lights, and other System elements specified in the Design Control Documents, have been deployed and activated in substantially all of such Coverage Area, the parties agree that Wireless Network performance problems and configuration problems and the inability of computers to receive wireless internet access from the Network will not constitute a Termination Default under this Section 12.1.1.

12.1.2 Failure to Pay Street Light Use Fees. It shall be a Termination Default by EL if EL fails to pay any of the payments provided in Section 7.1.1, *Prepayment of Street Light Use Fees* or in Section 7.1.2, *Monthly Street Light Use Fee*, within sixty (60) days after written notice of failure to pay when due is delivered to EL, provided that the notice must state that the failure to pay, if not cured, will constitute a Termination Default under this Agreement.

12.1.3 Network Outage. The following shall constitute a Termination Default by EL: If less than twenty percent (20%) of the receiving/transmitting nodes in the Wireless Network are capable of connecting Subscribers to the Internet for an entire calendar day, the Network will be considered "Dark" and that day will be considered a "Dark Day"; provided, that such day will not be considered a Dark Day if the failure to satisfy the above test was caused by WP, PAID, the City, providers of telecommunications service to the Network other than EL, providers of electricity to the Network, or by third parties (other than Subcontractors of EL) not under the control of EL, or by Force Majeure Events. If the System is continuously Dark for a period of thirty (30) or more days, PAID, at the direction of the City, may send a notice of termination, which shall be effective ninety (90) days after receipt by EL if such default has not been cured by the Network operating without any Dark Days for thirty (30) days continuously. If EL does cure the default by the Network operating without any Dark Days for thirty (30) days continuously prior to the end of such ninety (90) day period, then the termination shall not be effective and the defaults shall be cured. If EL is unable to cure the default within said ninety (90) days by the Network operating without any Dark Days for thirty (30) days continuously, then this Agreement and EL's authorization to use the Street Lights under the Agreement shall terminate twelve (12) months after the end of said ninety (90) day cure period; provided, that during such twelve (12) months EL will be entitled to continue operating the Network and the Communications Equipment on the Street Lights will not be removed, except as provided elsewhere in this Agreement. In addition, during such twelve (12) months, EL shall be entitled to sell the Communications Equipment; and provided the City, PAID and WP approve the purchaser and the assignment of EL's rights and interest in the Network (as provided in Section 17.16, *Assignment*, of this Agreement and in the assignment provision of the Network Agreement) to the transferee, EL shall also be entitled to transfer to a third party (subject to the terms of the foregoing assignment provisions) the Network, its ongoing operations, and EL's rights under this Agreement.

12.1.4 Removal of Communications Equipment Upon Termination for a Termination Default. Upon termination of this Agreement for a Termination Default, EL shall, at its own expense, within twelve (12) months of the date of termination, remove the Communications Equipment from the Street Lights and restore all Street Lights to at least the condition (taking into account normal wear and tear) they were in prior to the installation of the Communications Equipment. If EL fails to remove the Communications Equipment from the Street Light poles within twelve (12) months, the City shall have the right, but not the obligation, to remove any of the Communications Equipment so remaining, and EL shall reimburse the City for its costs incurred in connection with removing the Communications Equipment; provided, that if EL does not so reimburse the City within thirty (30) days following the City's written notice of its removal costs, the City may draw on the removal security provided in Section 8.5, *Removal Security*; and provided further that if sufficient funds remain of such removal security to pay storage costs after the payment of all costs incurred by the City to remove the Communications Equipment, the City will store the removed Communications Equipment in a location of the City's choice and give EL written notice that it has done so. If EL does not remove the Communications Equipment from the City's storage location within sixty (60) days following such notice, the City may dispose of the stored Communications Equipment in any manner that it chooses, without cost or liability to the

City. In no event shall the City be liable for theft or loss of or damage to the Communications Equipment, of any kind or nature whatsoever, that occurs during removal from the Street Lights, or while the Communications Equipment is in storage, whether or not such theft, loss, or damage is the result of any act or omission of the City.

12.2 Remedies for Noncompliance. In the event EL's use of a Street Light (including, without limitation, its installation, repair, replacement, operation, or maintenance of Communications Equipment on the Street Light) does not comply with the terms and conditions of the Sections listed below in this Section 12.2, PAID, at the direction of the Streets Commissioner, shall have the right to exercise any one or more of the remedies provided in Sections 12.2.1-.3, provided that EL has not corrected the noncompliance within fourteen (14) days following written notice from the Commissioner to EL describing the noncompliance in reasonable detail (or such longer period as the Commissioner may approve). The Commissioner shall have the right to exercise such remedies notwithstanding anything to the contrary in this Section 12 or elsewhere in the Agreement, and in addition to, not in lieu of, any other remedies available to the City and/or PAID at law or in equity (including, without limitation, application to a court of competent jurisdiction sitting in Philadelphia County for an injunction to enforce compliance), and in addition to, not in lieu of, any other rights of the City and/or PAID provided in this Agreement.

The Sections of the Agreement to which this Section 12.2 applies are:

- Section 2.4, *Authorized Communications Equipment*
- Section 2.5, *Conditions of City Issuance of Construction Permits*
- Section 2.6, *Maximum Number of Street Lights Authorized*
- Section 3, *Application and Approval to Place Communications Equipment*
- Section 4, *Construction Plans; Organization of the Work*
- Section 5, *Installation and Maintenance*
- Section 6, *Interruption to Service and Damage to Property*
- Section 8, *Insurance*

12.2.1 Termination. The Streets Commissioner may terminate EL's right to use a Street Light if EL's use of the Street Light, does not comply with the terms and conditions of the Sections of this Agreement set forth above as Sections to which Section 12.2 applies. EL shall remove its Communications Equipment from the Street Light within ten (10) days after receipt of the Commissioner's written notice of termination; if it does not do so, the Streets Department may remove the Communications Equipment at EL's expense and without liability to EL for loss or damage to the Communications Equipment. EL may not again use the Street Light without first obtaining a Construction Permit therefor, but nothing in this Section 12.2.1 will prohibit EL from applying for and obtaining a Construction Permit for a Street Light as to which it has been terminated.

12.2.2 Denial of Construction Permits. The Streets Commissioner may deny Construction Permits applied for after the expiration of the cure period(s) provided herein, provided the

non-compliance(s) for which this remedy is exercised are persistent and uncured after the applicable cure periods.

12.2.3 Money Payments. The Streets Commissioner may require EL to pay a sum of not more than seven hundred dollars (\$700) for each event of noncompliance that is not cured after the expiration of the cure period provided herein. A separate and distinct event of noncompliance, subject to the foregoing payment, shall be deemed committed on each day on which noncompliance occurs or continues.

12.3 Non-Termination Defaults. The following shall be events of default under this Agreement for which a non-defaulting party may exercise the remedies provided in Section 12.4, but only those remedies ("Non-Termination Defaults"). Termination of this Agreement and (in the case of EL) EL's authorization to use the Street Lights provided in the Agreement shall not be a remedy for any Non-Termination Default.

12.3.1 Failure to Meet Network Service Levels. The "non-termination defaults" provided in Section 16.4 of the Network Agreement, relating to Network service levels, shall also be Non-Termination Defaults under this Agreement.

12.3.2 EL's material failure to comply with any provision, term, or condition of this Agreement other than the terms set forth in Section 12.3.1, *Failure to Meet Network Service Levels*, or in the Sections of the Agreement identified in Section 12.1, *Termination for Termination Default* or Section 12.2, *Remedies for Noncompliance*, for which the default remedies are provided herein; provided, that such failure to comply shall not be an event of Non-Termination Default unless it remains uncured for thirty (30) days following delivery of the City's written notice of default.

12.3.3 PAID's material failure to comply with any provision, term or condition of this Agreement; provided, that such failure to comply shall not be an event of Non-Termination Default unless it remains uncured for thirty (30) days following delivery of EL's written notice of default.

12.4 Remedies for Non-Termination Default.

12.4.1 If an event of Non-Termination Default occurs, the non-defaulting party shall be entitled to exercise every remedy, other than termination of this Agreement (and in the case of EL other than termination of the authorizations to use the Street Lights provided in this Agreement), available to it under the law and under the Agreement, including without limitation specific performance, injunctive relief, and money damages; provided, however, that EL shall not have the right to exercise the remedies of specific performance or injunctive relief for any breach by PAID or the City of Section 2.2, *Authorization Not Exclusive*.

12.4.2 Equitable Relief. Each party agrees that any threatened or actual Non-Termination Default may cause immediate irreparable harm to the non-defaulting party for which there is no adequate remedy at law. Accordingly, each party agrees that the non-defaulting party will be entitled to an order for specific performance and to injunctive relief from a

court of competent jurisdiction as remedy for any threatened or actual Non-Termination Default. Except for the limitations on termination and injunctive relief that are stated in this Section 12, nothing herein will limit either party's right to any other remedies at law, including the recovery of money damages from the defaulting party. Nothing in this Section 12 or in Section 9.4, *Limitation of Liability*, will prevent or prohibit either party from obtaining an order of specific performance and an injunction from a court of competent jurisdiction requiring the defaulting party to comply with the provisions of the Agreement, and not to take actions that violate its obligations under the Agreement; provided, that such order shall not prevent EL from operating the Wireless Network and maintaining the Communications Equipment on the Street Lights, except in the event of termination for Termination Default or on account of expiration of the Initial Term and any Renewal Terms; and provided further that such order for specific performance and injunction shall not require either party to pay to the other party any sums in excess of the liability limitation set forth in Section 9.4. Notwithstanding anything to the contrary in this Section 12.4.2 or in Section 12.4.1, the Parties agree that EL shall not have the right to exercise the remedies of specific performance or injunctive relief for any breach by PAID or the City of Section 2.5, *Authorization Not Exclusive*.

12.4.3 **Termination by EL.** EL shall not terminate this Agreement or the Network Agreement, for default or otherwise, except that if the Network Agreement terminates pursuant to Sections 3.2(d), 4.4, 4.5, 10.3, 12.1, 16.3, 16.6 or 16.7 thereof, then this Agreement shall also terminate.

13 **Confidentiality.**

13.1 Except as permitted by this Agreement, neither Party will use the Confidential Information of the other. Each Party will use reasonable efforts, to the extent it does for its own proprietary and confidential information of like nature, to prevent any Confidential Information of the other Party from being disclosed to third parties except as set forth in this Agreement or as authorized by a Party in writing. EL acknowledges that as of the date of execution of this Agreement, it has not provided any Confidential Information to PAID and does not intend to provide any such information in the future. EL further acknowledges that PAID is a governmental agency subject to sunshine and Right-to-Know Act laws; PAID's obligations under this Section 13 are limited in all respects by applicable laws.

13.2 "Confidential Information" will mean a Party's trades secrets under applicable law and also the proprietary and confidential information disclosed to the other Party. PAID acknowledges that all information concerning EL, its business plans, pricing, proprietary rights, Subscribers, customers and suppliers will be deemed Confidential Information of EL, whether or not marked "CONFIDENTIAL", and will not be used or disclosed by PAID except in the proper performance of its obligations imposed by law or under this Agreement. Subject to applicable law, any obligation contained herein that requires the disclosure of information of a third Party shall not be required if it would violate an applicable agreement of a Party with that third Party. Each Party agrees that this Section is intended to protect the Confidential Information of the providers and Subcontractors of EL.

- 13.3 This Section 13 will not apply to any information which: (A) is or becomes public knowledge through no wrongful act of the receiving Party; (B) is already known to the receiving Party without obligation of confidentiality; (C) is rightfully obtained by the receiving Party from any third Party without similar restriction and without breach of any obligation owed to the disclosing Party; (D) is independently developed by the receiving Party; (E) is furnished to a third Party by the disclosing Party without a similar restriction on the third Party's rights; (F) is disclosed pursuant to a lawful requirement or request of a governmental agency; (G) is approved for release by written authorization of the disclosing Party; or (H) is disclosed in an enforcement or defense in a court of law pursuant to this Agreement or as is appropriate to assert and protect the rights of either Party. Despite the restrictions of this Section 13, EL and PAID shall each be entitled to provide the other's Confidential Information to third Party contractors and consultants that have executed a written confidentiality agreement containing substantially the provisions of this Section 13.
- 13.4 The provisions of this Section 13 shall survive for any trade secret for so long as such information qualifies as a trade secret under applicable law, and for three (3) years following the termination of this Agreement for Confidential Information that does not rise to the level of a trade secret. Upon any termination or expiration of this Agreement or as otherwise requested in writing by the disclosing Party, to the extent permitted by law, the receiving Party will return or destroy (as requested by the disclosing Party) all copies of the Confidential Information provided by the other Party and certify in writing that all copies of such Confidential Information have been returned or destroyed. Each Party shall be responsible for any use or disclosures by its employees or agents in violation of this Agreement. This Agreement and its Exhibits are not considered Confidential Information of either Party.
- 14 Interference. EL will not intentionally cause radio frequency interference or physical interference with the operation of radio device(s) of third parties that are lawfully installed on City Street Lights. The City and PAID will incorporate the foregoing prohibition against interference in agreements with others than EL authorizing the use of Street Lights for the installation and operation of radio devices that use unlicensed spectrum and will enforce the prohibition to the extent permitted by applicable law, but, subject to applicable law, neither the City nor PAID shall have any other obligation with respect to the prevention of such radio frequency interference.
- 15 Title and Quiet Enjoyment. Subject to the rights of the City and PAID in this Agreement, and provided that EL is in compliance with the Agreement, EL shall have quiet enjoyment of the designated Street Lights for the term of the Agreement.
- 16 NO WARRANTIES. THE ONLY WARRANTIES BY EITHER PARTY CONCERNING THE SERVICES, NETWORK, SYSTEM, STREET LIGHTS AND OTHER EQUIPMENT AND PROPERTY OF THE CITY OR PAID, AND OTHER DELIVERABLES, OBLIGATIONS OR RIGHTS PROVIDED UNDER THIS AGREEMENT ARE THOSE EXPRESSLY CONTAINED HEREIN, AND ARE MADE IN LIEU OF ALL OTHER WARRANTIES AND REPRESENTATIONS, EXPRESS OR IMPLIED, INCLUDING, BUT NOT LIMITED TO, ANY IMPLIED WARRANTIES OF MERCHANTABILITY AND FITNESS FOR A PARTICULAR PURPOSE OR OTHERWISE. EACH PARTY ALSO SPECIFICALLY DISCLAIMS ANY WARRANTIES OR REPRESENTATIONS RELATED TO THE INTERNET SECURITY-

RELATED FEATURES OF THE SYSTEM AND/OR SERVICES. NEITHER PARTY CAN GUARANTEE SECURITY VIA THE INTERNET OR WIRELESS SERVICES AND NEITHER PARTY SHALL BE LIABLE FOR BREACHES OF SUCH SECURITY OR ANY OTHER RELATED WARRANTIES, EITHER EXPRESSED OR IMPLIED, INCLUDING WITHOUT LIMITATION, INTERNET FUNCTION AND/OR PERFORMANCE WARRANTIES. NEITHER PARTY SHALL HAVE LIABILITY TO THE OTHER PARTY FOR THE CONDUCT OF SUBSCRIBERS USING OR ACCESSING THE NETWORK, SYSTEM OR SERVICES. NOTWITHSTANDING ANY OF THE FOREGOING, THIS LIMITATION OF LIABILITY SHALL IN NO MANNER LIMIT OR WAIVE ANY RIGHT OR OBLIGATION OF EITHER PARTY UNDER SECTIONS 8 (*INSURANCE; REMOVAL SECURITY*) OR 9 (*INDEMNIFICATION; INDEPENDENT CONTRACTOR; LIMITATION OF LIABILITY*) OF THIS AGREEMENT.

17 Miscellaneous Provisions.

- 17.1 Contract Documents; Order of Precedence. The contract documents shall consist of the body of this Agreement (Sections 1-17) and Exhibits A-D hereto. In the event of conflict or variance between the body of this Agreement (Sections 1-17) and any other Agreement Document, the body of this Agreement (Sections 1-17) shall govern. Conflicts and variances among the contract documents shall be resolved by giving precedence in the following order: (i) The body of this Agreement (Sections 1-17); (ii) Exhibits A-D, which shall be of even precedence with each other.
- 17.2 Business Privilege License. EL shall obtain, and shall require its Subcontractors to obtain, a valid business privilege license (issued by the City's Department of Licenses and Inspections) as required by The Philadelphia Code.
- 17.3 Non-discrimination. In performing this Agreement, EL shall not discriminate or permit discrimination against any person because of race, color religion national origin, gender, or sexual orientation, and shall not discriminate or permit discrimination against any person who has AIDS or is HIV-positive. In the event of such discrimination, in material violation of the provisions of the Philadelphia Code referenced in this Section 17.3, the City may, in addition to any other rights or remedies available under this Agreement, at law or in equity, terminate the Agreement if EL has not complied with this Section 17.3 within thirty (30) days following written notice of a violation. EL agrees, in performing this Agreement, to comply with the provisions of the Fair Practices Ordinance of The Philadelphia Code (Chapter 9-1100). EL agrees to cooperate with the Commission on Human Relations of the City of Philadelphia in any manner, which the Commission deems reasonable and necessary for the Commission to carry out its responsibilities under Chapter 17-400 of The Philadelphia Code. Failure to so cooperate shall constitute a substantial breach of this Agreement entitling the City to all rights and remedies provided herein or otherwise available at law or equity.
- 17.4 Chapter 17-1400. EL shall comply with the terms and conditions set forth in Exhibit D, *Provisions Required by Chapter 17-1400 of the Philadelphia Code*, For purposes of Exhibit D, "Provider" means EL.

- 17.5 The Philadelphia Code, Chapter 17-400. In accordance with Chapter 17-400 of The Philadelphia Code, as it may be amended from time to time, EL agrees that its payment or reimbursement of membership fees or other expenses associated with participation by its employees in an exclusionary private organization, insofar as such participation confers an employment advantage or constitutes or results in discrimination with regard to hiring, tenure of employment, promotions, terms, privileges or conditions of employment on the basis of race, color, sex, sexual orientation, religion, national origin or ancestry, constitutes an event of default under Section 12, *Default and Termination*, of the Agreement entitling the City to all rights and remedies provided in the Agreement or otherwise available at law or equity. EL agrees to include the immediately preceding subsection, with appropriate adjustments for the identity of the Parties, in all subcontracts which are entered into for work to be performed pursuant to the Agreement. EL further agrees to cooperate with the Commission on Human Relations of the City of Philadelphia in any manner which the Commission deems reasonable and necessary for the Commission to carry out its responsibilities under Chapter 17-400 of The Philadelphia Code. Failure to so cooperate shall constitute an event of default under Section 12, *Default and Termination*, of the Agreement entitling the PAID, at the direction of the City, to all rights and remedies provided therein or otherwise available at law or equity.
- 17.6 Federal Laws. EL shall comply with the applicable provisions of Title VI of the Civil Rights Act of 1964 (42 U.S.C. Section 2000d et seq.), Section 504 of the Federal Rehabilitation Act of 1973 (29 U.S.C. Section 794), The Age Discrimination Act of 1975, (42 U.S.C. Section 6101 et seq.), Title IX of the Education Amendments of 1972, (20 U.S.C. Section 1681), and 45 C.F.R. Part 92, as they may be amended from time to time, which together prohibit discrimination on the basis of race, color, national origin, sex, handicap, age and religion.
- 17.7 Americans With Disabilities Act. EL understands and agrees that in the performance of this Agreement, no individual with a disability shall, on the basis of the disability, be excluded from participation in the Agreement or from activities or Services provided under the Agreement. As a condition of accepting and executing the Agreement, EL shall comply with all provisions of the Americans With Disabilities Act, 42 U.S.C. §§12101 et seq., and all regulations promulgated thereunder, as the Act and regulations may be amended from time to time, which are applicable (a) to Contractor, (b) to the benefits, Services, activities, facilities and programs provided in connection with the Agreement, (c) to the City, or the Commonwealth of Pennsylvania, and (d) to the benefits, services, activities, facilities and programs of the City or of the Commonwealth, and, if any funds under the Agreement are provided by the federal government, which are applicable to the federal government and its benefits, services, activities, facilities and programs. Without limiting the generality of the preceding sentence, EL shall comply with the "General Prohibitions Against Discrimination", 28 C.F.R. §35.130, and all other regulations promulgated under Title II of "The Americans With Disabilities Act", as they may be amended from time to time, which are applicable to the benefits, services, programs and activities provided by the City through contracts with outsider contractors.
- 17.8 The Philadelphia Code, Section 17-104. In accordance with Section 17-104 of The Philadelphia Code, EL by execution of this Agreement certifies and represents that unless

EL has implemented the fair employment principles embodied in the MacBride Principles, (i) EL (including any parent company, subsidiary, exclusive distributor or company affiliated with Contractor) does not have, and will not have at any time during the term of this Agreement (including any extensions thereof), any investments, licenses, franchises, management agreements or operations in Northern Ireland and (ii) no product to be provided to the City under this Agreement will originate in Northern Ireland. In the performance of this Agreement, EL agrees that it will not utilize any suppliers, Subcontractors or subconsultants at any tier (i) who have (or whose parent, subsidiary, exclusive distributor or company affiliate have) any investments, licenses, franchises, management agreements or operations in Northern Ireland or (ii) who will provide products originating in Northern Ireland unless said supplier, subconsultant or Subcontractor has implemented the fair employment principles embodied in the MacBride Principles. EL further agrees to include the provisions of this Section 17.8, with appropriate adjustments for the identity of the parties, in all subcontracts and supply agreements which are entered into in connection with the performance of this Agreement. EL agrees to cooperate with the City's Director of Finance in any manner which the said Director deems reasonable and necessary to carry out the Director's responsibilities under Section 17-104 of The Philadelphia Code. EL expressly understands and agrees that any false certification or representation in connection with this Section 17.8 and/or any failure to comply with the provisions of this Section 17.8 shall constitute a substantial breach of this Agreement entitling the City to all rights and remedies provided in this Agreement or otherwise available in law (including, but not limited to, Section 17-104 of The Philadelphia Code) or equity. In addition, it is understood that false certification or representation is subject to prosecution under Title 18 Pa.C.S.A. Section 4904.

17.9 Executive Order 02-04: Gifts

17.9.1 Pursuant to Executive Order 02-04, no official or employee in the Executive and Administrative Branch of the City shall solicit or accept, directly or indirectly, anything of value, including any gift, gratuity, favor, entertainment or loan from any of the following sources:

17.9.2 Pursuant to Executive Order 02-04, no official or employee in the Executive and Administrative Branch of the City shall solicit or accept, directly or indirectly, anything of value, including any gift, gratuity, favor, entertainment or loan from any of the following sources:

- a) A person seeking to obtain business from, or who has financial relations with the City;
- b) A person whose operations or activities are regulated or inspected by any City agency;
- c) A person engaged, either as principal or attorney, in proceedings before any City agency or in court proceedings in which the City is an adverse party;
- d) A person seeking legislative or administrative action by the City; or
- e) A person whose interests may be substantially affected by the performance or nonperformance of the official's or employee's official duties.

17.9.3 Pursuant to Executive Order 02-04, no official or employee in the Executive and Administrative Branch of the City is entitled to solicit or accept, and EL

understands and agrees that if it offers anything of value to a City official or employee under circumstances where the receipt of such item would violate the provisions of this Executive Order, Provider shall be subject to sanctions with respect to future City contracts. Such sanctions may range from disqualification from participation in a particular contract to debarment, depending on the nature of the violation.

17.10 Certification of Non-Indebtedness.

EL hereby certifies and represents that EL, EL's parent company(ies), subsidiary(ies) and Subcontractors are not currently indebted to the City, and will not at any time during the term of this Agreement (including any extensions or renewals thereof) be indebted to the City, for or on account of any delinquent taxes (including, but not limited to, taxes collected by the City on behalf of the School District of Philadelphia), liens, judgments, fees or other debts for which no written agreement or payment plan satisfactory to the City has been established. In addition to any other rights or remedies available to the City at law or in equity, EL acknowledges that any breach or failure to conform to this certification may, at the option of the City, result in the withholding of payments otherwise due to EL and, if such breach or failure is not resolved to the City's satisfaction within a reasonable time frame specified by the City in writing, may result in the offset of any such indebtedness against said payments and/or the termination of this Agreement for default (in which case EL shall be liable for all excess costs and other damages resulting from the termination in accordance with Section 12, *Default and Termination*; provided, however, that if the breach or failure to conform is by a Subcontractor of EL (at any tier), the Agreement shall not be terminated if EL pays to the City the amount of the taxes, liens, judgments, fees or other debts owed to the City by the Subcontractor and constituting the basis for the breach or failure to conform.

17.11 Compliance with Law and Regulations. All work performed and services rendered shall strictly conform to all laws, statutes, and ordinances and the applicable rules, regulations, methods and procedures of all governmental bodies, boards, bureaus, office commissions and other agents.

17.12 Coordination of Public Statements. During the period prior to City Council's final approval of this Agreement, EL and PAID agree to meet regularly with the City and WP, or to talk by phone regularly, to coordinate the public statements that both will make during the City Council approval process. As part of this coordination the parties will exercise reasonable efforts to send a copy of press releases related to the Agreement and the Wireless Network to the other party before they are published to the extent there is sufficient time to comply with applicable law. Notwithstanding anything to the contrary, either party may make the statements it believes to be in its best interest or as is required to fulfill the obligations of that party or is required by law.

17.13 Non-solicitation. Neither party shall solicit the employment of any employee of the other party who has been assigned responsibilities under this Agreement, nor shall EL so solicit any such employee of the City, for the period of six (6) months following termination of responsibilities of each such employee; provided, that the prohibition in this Section 17.13

shall not apply to general advertisements of employment opportunities that are not directed to PAID or City employees.

17.14 Prevailing Wages. Contracts resulting from this Agreement shall require the payment of prevailing wages. Accordingly, employees of EL and its contractors performing work that would be subject to Section 17-107 of the Philadelphia Code, if performed for the City of Philadelphia, shall be paid at least the applicable prevailing wages for the respective occupational classifications designated in Section 17-107, in accordance with its requirements.

17.15 Survival. Any and all provisions set forth in the Agreement which, by its or their nature, would reasonably be expected to be performed after the termination of the Agreement shall survive and be enforceable after such termination, including, without limitation, the following:

17.15.1 Any and all liabilities, actual or contingent, which shall have arisen in connection with the Agreement;

17.15.2 EL's representations and covenants set forth herein;

17.15.3 Those Sections referenced in Section 12.4.3.

17.15.4 The following Sections:

- Section 1, *Definitions*
- Section 2.7, *Conditions of the Obligations of the Parties*
- Sections 2.8 through 2.11, but only until all Communications Equipment is removed from all Street Lights
- Section 2.14, *Compliance With Law*
- Section 3.1, *Construction Permits Required*
- The following subsections of Section 5, *Installation and Maintenance*, but only until all Communications Equipment is removed from all Street Lights in accordance as required under the Agreement:
 - 5.1.2
 - 5.2-5.5
 - 5.7
 - 5.10
- Section 6, *Interruption to Service and Damage to Property*, but only until all Communications Equipment is removed from all Street Lights as required under the Agreement:
- The following subsections of Section 7, *Compensation*:
 - 7.1 through 7.1.2
 - 7.2 through 7.4
- Sections 8.1 through 8.4, *Insurance*, but provided that EL's insurance coverages are written on an "occurrence" basis, only until the earlier of (i) all Communications Equipment is removed from all Street Lights as required under this Agreement, or (ii) EL's letter of credit is required to be returned or cancelled under Section 8.5.; and if insurance coverages are not all written on an "occurrence" basis, then until the

expiration of all applicable statutes of limitations on lawsuits arising under this Agreement.

- Section 8.5, *Removal Security*, but only until the earlier of (i) all Communications Equipment is removed from all Street Lights as required under this Agreement, or (ii) EL's letter of credit is required to be returned or cancelled under Section 8.5.
- Section 9, *Indemnification; Independent Contractors; Limitation of Liability*
- Section 10, *Dispute Escalation*
- Section 11.3, *Expiration and Removal*
- Section 12, *Default and Termination*
- Section 13, *Confidentiality*
- Section 16, *No Warranties*
- The following subsections of Section 17, *Miscellaneous Provisions*
 - 17.11, *Compliance with Law and Regulations*
 - 17.14, *Prevailing Wages*
 - 17.15, *Survival*
 - 17.16, *Assignment*
 - 17.17, *Notices*
 - 17.18, *Governing Law*
 - 17.19, *Forum; Consent to Jurisdiction*
 - 17.20, *PAID's Expenses*
 - 17.23, *Third Party Beneficiaries*
 - 17.25, *No Waiver*
 - 17.28, *Agreement Drafted by All Parties*
 - 17.30, *Severability and Partial Invalidity*
 - 17.31, *Force Majeure*
 - 17.32, *Entire Agreement*

17.16 Assignment. EL shall not assign this Agreement, or any portion of it, without the prior written permission of PAID and the City, which permission may be withheld in their complete discretion, and any such assignment made without such consent shall be void and shall not operate to relieve EL from any of its obligations or liabilities under this Agreement; provided, that EL is entitled to assign this Agreement without the consent of PAID and the City pursuant to the sale or transfer of all or substantially all of the assets or stock of EL, or pursuant to a transfer or assignment pursuant to a reorganization or merger or assignment to a subsidiary that is wholly or majority owned and controlled by EL; provided, that EL shall remain responsible for defaults or damages under the Agreement caused by such entity and for such entity's performance of the Agreement. PAID, with the City's approval but otherwise in PAID's sole discretion and upon written notice to EL, may assign the Agreement to another City-related authority or agency created pursuant to the Pennsylvania Municipal Authorities Act of 1945, as amended, or the Pennsylvania Economic Development Financing Law, Act No. 102, approved April 23, 1967, as amended, that has substantially the same powers, purposes, and authority as has PAID, including the power and authority to enter into and to carry out and perform this Agreement.

17.17 Notices. Any notice required or permitted to be given under the Agreement shall be given in writing and shall be personally delivered by hand with receipt obtained, by a national

overnight express carrier (such as Federal Express), by facsimile (with copy by registered or certified United States mail) or by registered or certified United States mail, return receipt requested, addressed as follows:

IF TO PAID:

Philadelphia Authority for Industrial Development
c/o Philadelphia Industrial Development Corporation
Attn.: Samuel V. Rhoads, Sr. Vice President
2600 Centre Square West
1500 Market Street
Philadelphia, PA 19102-2126

With copies to:

City Solicitor
1515 Arch Street, 17th Floor
Philadelphia, PA 19102

IF TO EL:

EarthLink, Inc.
1375 Peachtree Street, Level A
Atlanta, Georgia 30309
Attention: General Counsel
Facsimile: 404-287-4905

With a copy to:

EarthLink, Inc.
1375 Peachtree Street, Level A
Atlanta, Georgia 30309
Attention: VP of Municipal Wireless Division
Facsimile: 404-287-1059

IF TO CITY:

Managing Director
City of Philadelphia
Municipal Services Building, Suite 1430
1401 JFK Boulevard
Philadelphia PA 19102

With copies to:

Commissioner

Department of Streets
Municipal Services Building, Suite 730
1401 JFK Boulevard
Philadelphia PA 19102

and

City Solicitor
1515 Arch Street, 17th Floor
Philadelphia, PA 19102

17.18 Governing Law. The Agreement and all disputes arising under the Agreement shall be governed, construed and decided in accordance with the laws of the Commonwealth of Pennsylvania.

17.19 Forum; Consent to Jurisdiction. The Parties agree that any lawsuit, action, claim, or legal proceeding involving, directly or indirectly, any matter arising out of or related to this Agreement, or the relationship created or evidenced thereby, shall be brought exclusively in the United States District Court for the Eastern District of Pennsylvania (“EDPA”) or in a Pennsylvania state court sitting in Philadelphia County. It is the express intent of the Parties that jurisdiction over any lawsuit, action, claim, or legal proceeding shall lie exclusively in one of these forums. The Parties further agree not to raise any objection, as to forum or venue, to any lawsuit, action, claim, or legal proceeding which is brought in one of these forums, and the Parties expressly consent to the jurisdiction and venue of these forums. Nothing in this Section 17.19 shall be construed to waive the right of either Party to remove any action brought in a Pennsylvania state court to the EDPA if otherwise permitted by law.

17.20 PAID’s Expenses. PAID shall have no obligation to take any action which it is permitted or required to take under this Agreement, whether at the direction of the City or EL, unless all reasonable costs and expenses of PAID, including its reasonable attorneys fees, are paid as incurred by the directing party.

17.21 Authority

17.21.1The City/PAID Street Light Use Agreement shall contain the following representation:

The City represents that the City has reasonably concluded that: (i) subject to the condition that City Council approves the City/PAID Street Light Use Agreement by ordinance and the ordinance becomes law, the City has the requisite power and authority to execute and deliver and to carry out and perform the City/PAID Street Light Use Agreement, and to grant to PAID the right to enter into and to carry out and perform the EL/PAID Street Light Use Agreement; (ii) the City has no actual knowledge of, nor has it received any legal notice of, any fact, act or omission which is inconsistent with this conclusion; and (iii) subject to the condition that City Council approves the City/PAID Street Light Use Agreement by ordinance and the ordinance becomes law, its execution and delivery by the City is duly and validly authorized by all

necessary action, and when executed and delivered, is the legal, valid, and binding obligation of the City, enforceable in accordance with its terms. The City hereby authorizes PAID to grant to EL the right to rely on this representation.

17.21.2 PAID grants to EL the same right to rely on the representation of the City provided in Section 17.21.1 that PAID has pursuant to the City/PAID Street Light Use Agreement.

17.21.3 EL represents that (i) it has the requisite power and authority to execute and deliver and to carry out and perform the Street Light Use Agreement; (ii) it has no actual knowledge of, nor has it received any legal notice of, any fact, act or omission which is inconsistent with this conclusion; and (iii) its execution and delivery by EL is duly and validly authorized by all necessary action, and when executed and delivered, is the legal, valid, and binding obligation of EL, enforceable in accordance with its terms.

17.21.4 EL grants to the City the same right to rely on the representation of EL provided in Section 17.21.3 that PAID has pursuant to this Agreement and hereby authorizes PAID to grant to the City the right to rely on such representation in the City/PAID Agreement.

17.22 Expiration of PAID. In the event that during the Term of this Agreement, the existence of the Authority is not renewed or extended pursuant to Applicable Law or the Authority otherwise ceases to exist, and a successor to the Authority with at least the same rights, obligations and sources of funding as the Authority hereunder is not established, all rights and obligations of the Authority under this Agreement shall automatically vest in the City without any further action by the parties hereto and the City shall be bound by all of the terms and conditions applicable to the Authority under this Agreement.

17.23 Third Party Beneficiaries.

17.23.1 Provided that the City is bound by the terms and conditions of this Agreement as PAID is bound, EL and PAID expressly agree that the City is an intended third party beneficiary of this Agreement and shall be entitled to enforce the terms and conditions of the Agreement (subject to and in accordance therewith) in the City's own name and on its own behalf against either or both of EL and PAID. Such rights of the City as third party beneficiary shall vest immediately upon execution of this Agreement and may not be modified or diminished except with the written consent of the City. Except as expressly provided otherwise in this Section 17.23 and elsewhere in the Agreement, nothing in the Agreement, express or implied, is intended or shall be construed to confer upon or give to any person, firm, corporation, or legal entity, other than EL, PAID and the City, any rights, remedies, or other benefits under or by reason of the Agreement.

17.23.2 PAID and EL shall not breach, terminate or amend this Agreement in any way that would materially diminish or adversely and materially affect the grants to the City, the rights of the City, or the obligations of EarthLink or PAID to the City, that are set forth in this Agreement.

17.24 EL Third Party Beneficiary of City/PAID Agreement.

PAID agrees that the following provision shall be included in the City/PAID Street Light Use Agreement:

19 Third Party Beneficiaries.

- 19.1 PAID and the City expressly agree that EL is an intended third party beneficiary of the obligations of the City under the following Sections of this Agreement (collectively, the “EL Enforceable Provisions”): Section 2 (*Authorization; City Obligations*); Section 4 (*Term*); Sections 6.1 and 6.2 (*City Covenants*); Section 7 (*Representation of Authority*); Section 15 (*Survival*), but only as to the EL Enforceable Provisions that are set forth in Section 15; Section 17 (*Assignment*), but only as to clauses (ii) and (iii); Section 18 (*Notices*); this Section 19; and Sections 20.1-20.11 (*Miscellaneous*), but only to the extent directly related to and a condition to the enforcement of the provisions as to which EL has been expressly given third party beneficiary rights under this Section 19.1.

EL shall be entitled to enforce the terms and conditions of the EL Enforceable Provisions (subject to and in accordance therewith, and as to PAID and the City, subject to their respective limitations of liability set forth in the EL/PAID Agreement) in its own name and on its own behalf against either or both of the City and PAID, provided that in the exercise of such rights, (i) EL is bound by the terms and conditions of this Agreement as PAID and the City are bound thereby, provided, however, that the liability disclaimers provided with respect to PAID and the City in Section 16, *No Personal Liability*, shall not preclude EL's enforcement of the EL Enforceable Provisions against the City, and (ii) such rights may only be exercised in accordance with Section 19.2.

The foregoing rights of EL as third party beneficiary shall, subject to the conditions set forth in Section 19.2, vest immediately upon the Effective Date of this Agreement, and may not be modified or diminished except with the written consent of EL. Except as expressly provided otherwise in this Section 19 or elsewhere in this Agreement, nothing in this Agreement, express or implied, is intended or shall be construed to confer upon or give to any person, firm, corporation, or legal entity, other than PAID, the City and EL any rights, remedies, or other benefits under or by reason of the Agreement. PAID and the City agree that EL shall be entitled to exercise specific performance and all equitable remedies, except as provided in Section 19.3 below.

- 19.2 The rights of EL as third party beneficiary set forth in Section 19 shall be effective only if all of the conditions provided in Sections 19.2.1 and 19.2.2 are satisfied:

- 19.2.1 In the event that EL believes the City has by its act or omission failed to perform any of its duties or obligations as specified in the EL Enforceable Provisions or caused PAID to be in breach of the EL/PAID Agreement, then EL must certify the

same to PAID and the City in writing and must assert in the certification EL's written demand that PAID enforce such duties or obligations of this Agreement against the City.

19.2.2 Upon receipt of such certification, PAID shall within twenty-five (25) days of such certification (or such earlier time as is reasonably specified in the certification if the certification reasonably states that irreparable damage is imminent) either (i) at EL's cost and using attorneys approved by EL, institute legal proceedings to enforce the City's duties or obligations as specified in the EL/PAID Agreement and in the EL Enforceable Provisions; or (ii) notify EL that it will not institute such legal proceedings. If PAID notifies EL that it will not institute such legal proceedings, or if, without such notification, PAID does not start such proceedings within the times specified above and/or does not then diligently and expeditiously pursue such proceedings, then the third party beneficiary rights of EL set forth in this Section 19 shall immediately be effective without further action on the part of PAID or EL and EL may thereafter institute such legal proceedings against the City in its own name.

19.3 Notwithstanding anything to the contrary in this Section 19 or elsewhere in this Agreement, or in the EL/PAID Agreement, EL shall not have the right under this Section 19 or otherwise under this Agreement to specific performance or any equitable remedy, including, without limitation, injunctive relief, against the City or PAID for the City's or PAID's failure to comply with Section 2.2 (*Authorization Not Exclusive*) of the EL/PAID Agreement or any provision of similar effect in this Agreement.

19.4 PAID and the City shall not breach, terminate or amend this Agreement or the EL/PAID Agreement in any way that would materially diminish or adversely and materially affect the grants to EarthLink, the rights of EarthLink, or the obligations of PAID to EarthLink, that are contained in the EL/PAID Agreement.

19.5 The City acknowledges that these provisions may operate for the benefit of EarthLink.

17.25 No Waiver. No delay or omission by either party hereto to exercise any right or power occurring upon any noncompliance or default by the other party with respect to any of the terms of this Agreement shall impair any such right or power or be construed to be a waiver thereof. A waiver by either of the parties hereto of any of the covenants, conditions, or agreements to be observed by the other shall not be construed to be a waiver of any succeeding breach thereof, or of any other covenant, condition, or agreement herein contained. Unless stated otherwise, all remedies provided for in this Agreement shall be cumulative and in addition to, and not in lieu of, any other remedies available to either party at law, in equity, or otherwise.

17.26 Notification. The City will with reasonable promptness notify EL of its receipt, subsequent to the execution of this Agreement, of applications by others for authorization to install a wireless internet access network on City Street Lights, where the circumstances of the

applicant and the proposed wireless network are in material respects similar to the circumstances of EL and the Wireless Network. Notwithstanding Section 17-17, *Notices*, such notice may be delivered by City attorneys to EL attorneys, and may be given by electronic mail or telephone.

17.27 Counterparts. This Agreement may be executed in counterparts, each of which shall be on paper and each of which shall be deemed an original, and all of which shall constitute one instrument; provided, that the Agreement shall be effective and binding on the parties upon, but only upon, the execution by each party of one paper copy hereof.

17.28 Agreement Drafted by All Parties. This Agreement is the result of arms-length negotiations between the parties. The body of the Agreement (Sections 1-17) shall be deemed to be drafted by both parties and any ambiguities in the Agreement shall accordingly not be construed against either party.

17.29 Headings, Table of Contents Not Controlling. The table of contents and headings used in this Agreement are for reference and convenience only, do not in any way define, limit, describe or amplify the provisions of the Agreement or the scope or intent of its provisions, are not a part of the Agreement, and will not enter into its interpretation.

17.30 Severability and Partial Invalidity. Except as provided below, the provisions of this Agreement shall be severable; and if any provision of the Agreement, or the application thereof, for any reason or circumstance, is to any extent held to be invalid or unenforceable, the remaining provisions of the Agreement (as well as the application of all provision(s) that were held to be invalid or unenforceable to persons or entities other than those as to which they were held invalid or unenforceable) shall not be affected or impaired thereby; and each provision of the Agreement shall be valid and enforceable to the fullest extent permitted by law. Notwithstanding the foregoing, if the authorization to use Street Lights provided in this Agreement is terminated by PAID, or by order of a court of competent jurisdiction (following appeal and final disposition), or is prohibited by the enactment into law of a valid and enforceable federal, state, or local statute, all without EL's fault or EL's default of the Agreement, then EL shall have no obligation to pay to the City any dollar amounts provided in the Agreement that are due and owing to the City after the date of such termination.

17.31 Force Majeure. In the event that either party is unable to perform any of its obligations under this Agreement because of a Force Majeure event, as defined in this Section, the party that has been so affected shall immediately give notice to the other party; and shall exercise every commercially reasonable effort to resume performance of its obligations. Neither party shall be in default under Section 12, *Default and Termination*, if its failure to perform is the result of a Force Majeure Event and is without its fault or negligence, and the time for a party's performance shall be deemed extended by the time lost due to delay resulting from a Force Majeure Event. "Force Majeure Event" shall mean and include the following: acts of God, acts of third parties that are beyond a party's control, acts of terrorism, strikes, civil riots, floods, material or labor restrictions by governmental authority, failures by providers of telecommunications service to the Wireless Network

(other than EL), failures by providers of electricity to the Network, court order or change in applicable law prohibiting performance, or any other cause beyond a party's control.

17.32 Entire Agreement. This Agreement contains the entire agreement between the parties with respect to the subject matter hereof; supersedes all prior negotiations, agreements, and undertakings between the parties with respect to such subject matter; and cannot be changed, modified or amended except by agreement on paper and in writing signed by both parties. The parties hereto bind themselves, their heirs, executors, administrators, successors and assigns for the faithful performance of this Agreement.

IN WITNESS WHEREOF, the Parties grant, acknowledge and accept the terms, conditions and obligations of this Agreement as evidenced by the following signatures of their duly authorized representatives. It is the intent of the Parties that this Agreement shall become operative on the Effective Date.

EARTHLINK, INC.

By: _____
Name: _____
Title: _____

**THE PHILADELPHIA AUTHORITY FOR INDUSTRIAL
DEVELOPMENT**

By: _____
Name: _____
Title: _____

EXHIBIT A

**AUTHORIZED COMMUNICATIONS EQUIPMENT
SPECIFICATIONS AND INSTALLATION METHODS**

Images, Diagrams and Specifications for the Tropos 5210 Outdoor MetroMesh Router

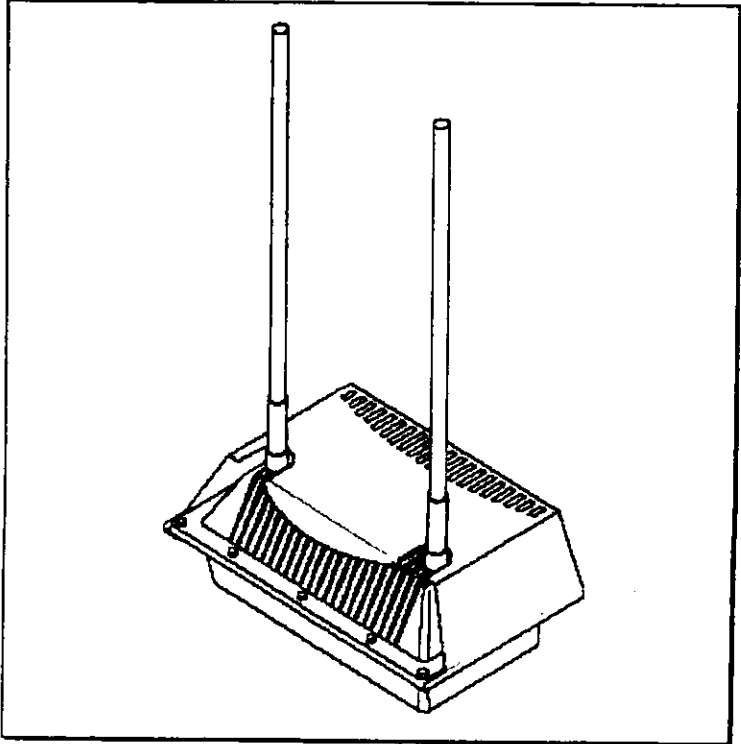
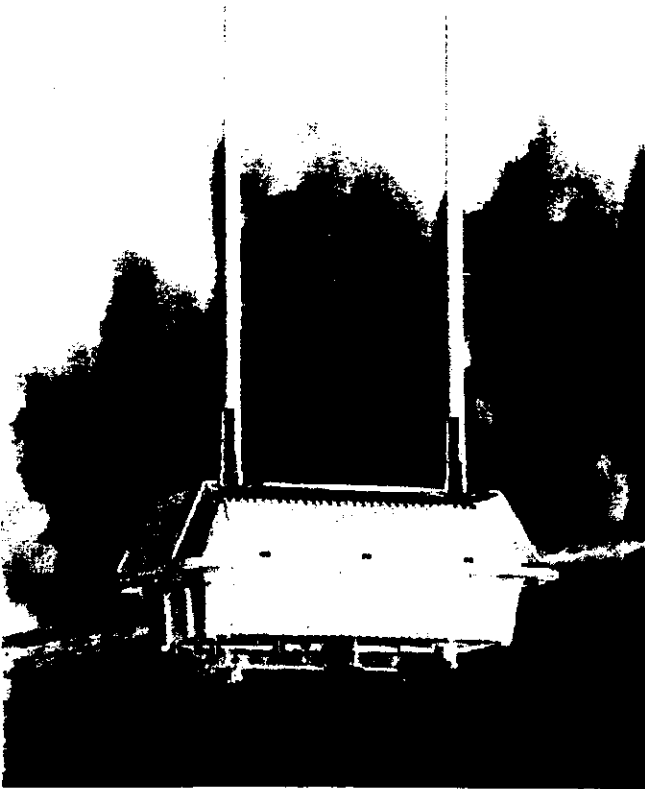

Tropos 5210 Wi-Fi Node with Attached Motorola Canopy Subscriber Module

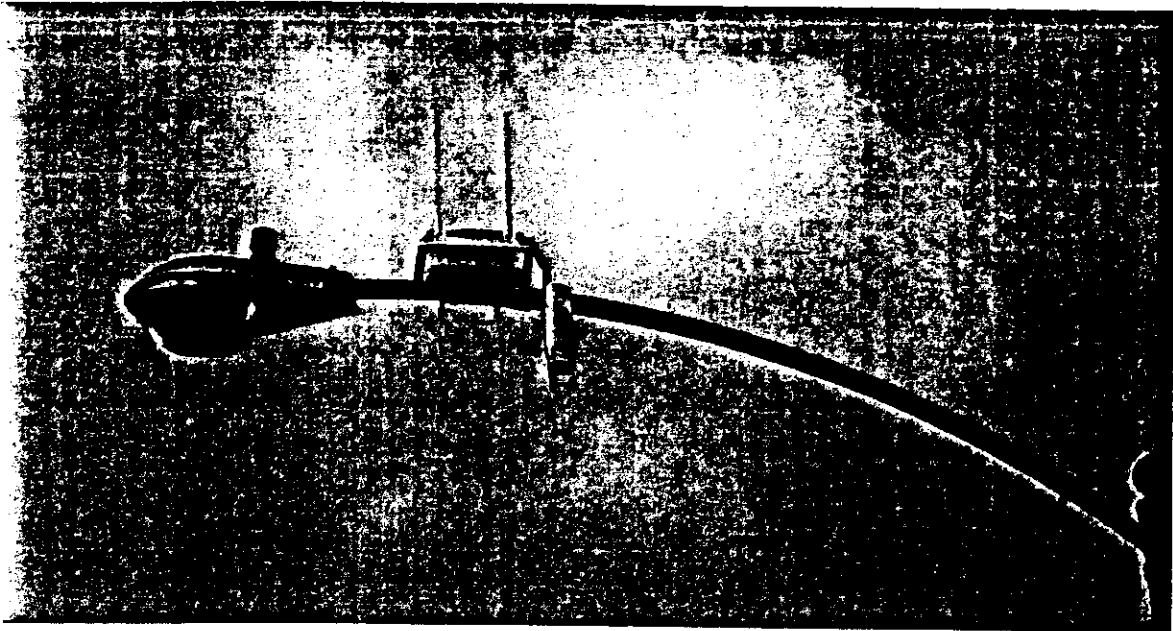

Tropos 5210 Wi-Fi Cell Exploded View

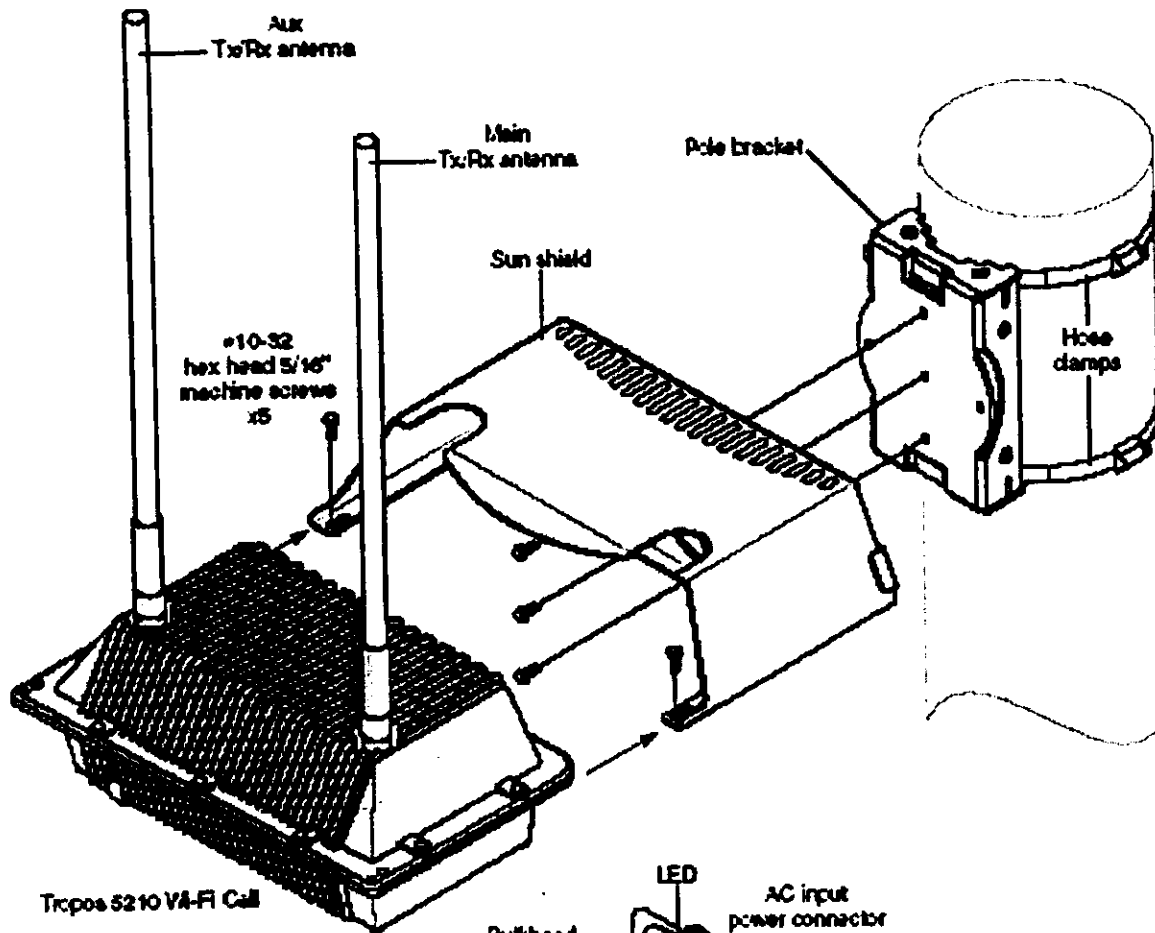

Tropos 5210 Wi-Fi Cell

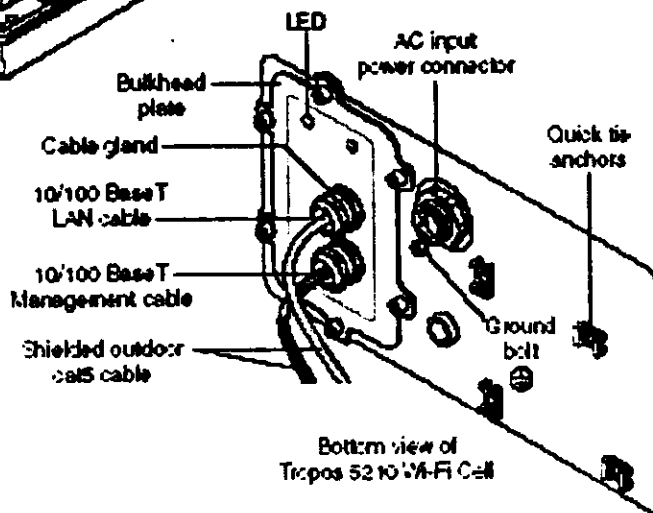

Bottom view of Tropos 5210 Wi-Fi Cell

Tropos 5210 Wi-Fi Node Specifications

DESCRIPTION	TROPOS 5210 WI-FI NODE
Wireless	<ul style="list-style-type: none"> • IEEE 802.11b/g • Frequency band: 2.4-2.483 GHz • Modulation: 802.11g - OFDM (64-QAM, 16-QAM, QPSK, BPSK) • 802.11b - DSSS (DBPSK, DQPSK, CCK) • TX Power: <ul style="list-style-type: none"> ▪ Standard 14dBm-24dBm (EIRP) factory-set in 1dB units ▪ High-Power 26dBm-36dBm (EIRP) factory-set in 1dB units • 7.4dBi Omni directional antennas • Media Access Protocol: CSMA/CA with ACK • Transmit and Receive diversity • RX Sensitivity: <ul style="list-style-type: none"> ▪ -100dBm @ 1 Mbps ▪ -94dBm @ 5.5 Mbps ▪ -92dBm @ 11 Mbps ▪ -95dBm @ 6 Mbps ▪ -93dBm @ 12 Mbps ▪ -90dBm @ 18 Mbps ▪ -87dBm @ 24 Mbps ▪ -84dBm @ 36 Mbps ▪ -79dBm @ 48 Mbps ▪ -77dBm @ 54 Mbps
Networking	<ul style="list-style-type: none"> • TCP and VPN session persistent roaming • Full 802.11b/g client compatibility • NAT support • Layer 2 and Layer 3 support • DHCP Server and Relay • Sub-interface support • Ethernet port
Management	<ul style="list-style-type: none"> • HTTPS to on-board configuration management tools • Secure local and remote configuration via HTTPS • SNMP V2c • Tropos MIB • Browser-based management tool • Simple configuration save and restore • Network & client monitoring and statistical capture features
Security	<ul style="list-style-type: none"> • WPA - (64, 128, 152-WEP with TKIP) • Multiple ESSIDs • Full VPN compatibility • VPN filtering—rejects non-VPN traffic • MAC address access control lists • HTTPS only to on-board management tools • AES encryption of wireless routing • Packet filtering • ESSID suppression

DESCRIPTION	TROPOS 5210 WI-FI NODE
Environmental Specifications	<ul style="list-style-type: none"> • Operating temperature range: -40°C to 55°C • Storage temperature range: -40°C to 85°C • Weather rating: IP67 weathertight • Wind survivability: >165 mph • Wind loading (165 mph): <1024 Newtons • MIL-STD-810F 509.4 Salt Fog rust resistance compliant • Shock & vibration: ETSI 300-19-2-4 spec T41.E class 4M3 • Transportation: ISTA 2A
Optional Battery Back-Up	<ul style="list-style-type: none"> • Factory Installed Li-Ion battery • Back-up power 4-12 hours typical
Optional Accessories	<ul style="list-style-type: none"> • Power Cables • Street light NEMA photo-electric control power tap 90-480 V • AC, 2 wire 4 ft. power cable • Street light NEMA photo-electric control power tap 90-480 V AC, 2 wire 20 ft. power cable • Electrical power cord, US/Canada 120 VAC, 15 A, 3 prong 6 ft. or 30 ft. • CAT5 building entrance data protection; network protection unit
Package Contents	<ul style="list-style-type: none"> • Tropos 5210 • Mounting bracket and accessories • Hardware Installation and Quick Start Guides
Approvals	<ul style="list-style-type: none"> • FCC CFR 47 Part 15, Class B • Industry Canada RSS 210 • Taiwan DGT LP0001/LP0002 • VCCI class B • ARIB STD-T66 • EN 301 489-17 • EN 300 328 • EN 60 950 • IEC 950 • UL 60950-1 • CSA 22.2 No. 950 • UL 579/IEC 60529 IP67 rated for outdoor use • UL 1449/IEC 60 664-1 • CE
Hardware Specifications	<ul style="list-style-type: none"> • Autosensing 10/100BaseT Ethernet • Power input: 90-480VAC 50/60Hz single and split-phase ANSI/IEEE C62.41 category C3 integrated branch circuit protection • AC power consumption: 18 W typical • Power over Ethernet power sourcing capability: 12Vdc @ 14W, 24Vdc @ 12W, 48Vdc @ 10W output • Power-on and network status lamp: Green/Red • Dimensions (w/o mounting brackets or antennas): 13.00 in (33.02 cm) wide x 8.00 in (20.32 cm) deep x 5.3 in (13.50 cm) high • Weight: 14 lbs (6.40 kg) max., with mounting brackets

DESCRIPTION	TROPOS 5210 WI-FI NODE
Protection Circuits	<ul style="list-style-type: none"> • Antenna Protection: $\leq 0.5\mu\text{J}$ for 6kV/3kA @ 8/20μS Waveform • Electrical Protection: <ul style="list-style-type: none"> ▪ ANSI/IEEE C62.41, UL 1449-2nd ed., 10kA @ 8/20 μS Wave form, 36kA per phase, L-L, L-N, L-PE ▪ EN61000-4-5 Level 4 AC Surge Immunity ▪ EN61000-4-4 Level 4 Electrical Fast Transient Burst Immunity ▪ EN61000-4-3 EMC Field Immunity • Data Protection: EN61000-4-2 Level 4 ESD Immunity
Warranty	<ul style="list-style-type: none"> • One (1) year on parts and labor; return to point of purchase • Optional standard and premium support packages available

Images, Diagrams and Specifications for the Motorola Canopy Advantage 5.7 GHz Subscriber Module

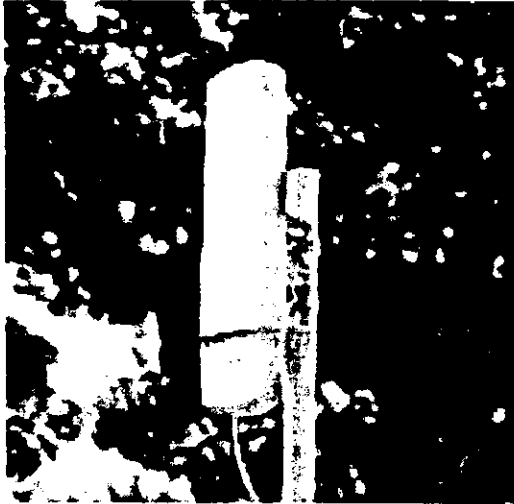

Motorola Canopy Advantage 5.7 GHz Subscriber Module Specifications

Canopy Part Number	5750SM
Description	5.7 GHz Advantage SM
Market Availability	North America, Latin America, Asia
Signaling Rate	20 Mbps Maximum
Typical LOS Range	2 Mile (3.2 km) max
Typical Aggregate Useful Throughput	14 Mbps to 1 Mi
Frequency range of band	ISM 5725-5850 MHz
Non-overlapping Channels	6
Channel Width	20 Mhz
Channel Spacing	every 5 MHz
Modulation Type	High Index 2-level Frequency Shift Keying (FSK) optimized for interference rejection
Encryption	DES capable
Latency	5 - 7 msec
Carrier to Interference ratio (C/I)	~3dB @ 10 Mbps, ~10dB @ 20 Mbps at -65dBm
Nominal Receiver Sensitivity (dbm typical)	-86 dB

Images, Diagrams and Specifications for the Motorola Canopy Advantage 5.2 GHz Subscriber Module

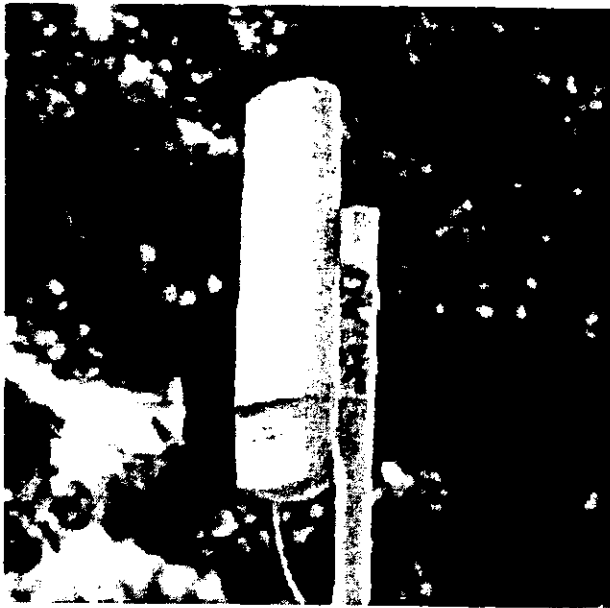

Motorola Canopy Advantage 5.2 GHz Subscriber Module Specifications

Canopy Part Number	5250SM
Description	5.2 GHz Advantage SM
Market Availability	North America
Signaling Rate	20 Mbps Maximum
Typical LOS Range	2 Mi Max
Typical Aggregate Useful Throughput	14 Mbps Maximum
Frequency range of band	U-NII 5250-5350 MHz
Non-overlapping Channels	3
Channel Width	20 MHz
Channel Spacing	every 5 MHz
Modulation Type	High Index 2-level Frequency Shift Keying (FSK) optimized for interference rejection
Encryption	DES capable
Latency	5 - 7 msec
Carrier to Interference ratio (C/I)	~3dB @ 10 Mbps, ~10dB @ 20 Mbps at -65dBm
Nominal Receiver Sensitivity (dbm typical)	-86 dBm

Antenna Gain (dB)	7 dB
EIRP (dB)	30 dB
Equivalent Isotropic Radiated Power (EIRP)	1W
DC Power (typical)	0.3 A @ 24 VDC = 7.2 W
Antenna Beam Width	3 dB antenna beam width 60 degrees, Azimuth and Elevation
Temperature	-40° C to +55° C (-40° F to +131° F)
Wind Survival	190 km/hr (118 miles/hr)
Dimensions	11.75 in H x 3.4 in W x 3.4 in D (29.9 cm H x 8.6 cm W x 8.6 cm D)
Weight	.45 kg (1 lb)
Access Method	Time Division Duplexing/Time Division Multiple Access (TDD/TDMA)
Interface	10/100 Base T, half/full duplex. Rate auto negotiated (802.3 compliant)
Protocols Used	IPV4, UDP, TCP, ICMP, Telnet, HTTP, FTP, SNMP
Network Management	HTTP, TELNET, FTP, SNMP Version 2c
FCC ID	ABZ89FC5804
Industry Canada Certification Number	109W-5700
NYCE	0202CE08128

Install the Canopy SM Mounting arm

1. Orientate the mounting arm onto the desired side of the Tropos 5210 Sun Shield, and mount with the three long screws into the corresponding holes.
2. Attach the Canopy SM module to the end of the Mounting Arm with appropriate clamps.

Installing the Canopy SM Mounting arm

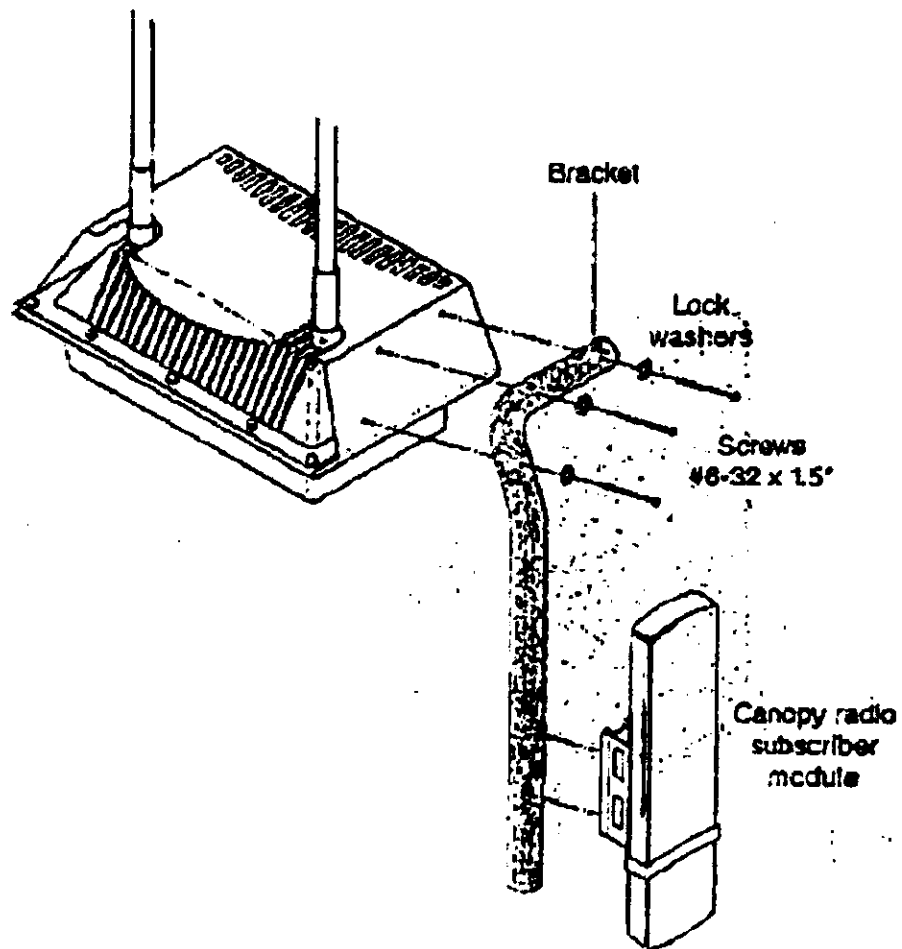

3. Verify that the power cable is disconnected on the designated Tropos unit.
4. Remove the connector access cover from the bottom of both the Tropos 5210, and from the Canopy SM.

Connecting Cat 5 Ethernet Cable from Canopy to Tropos Node

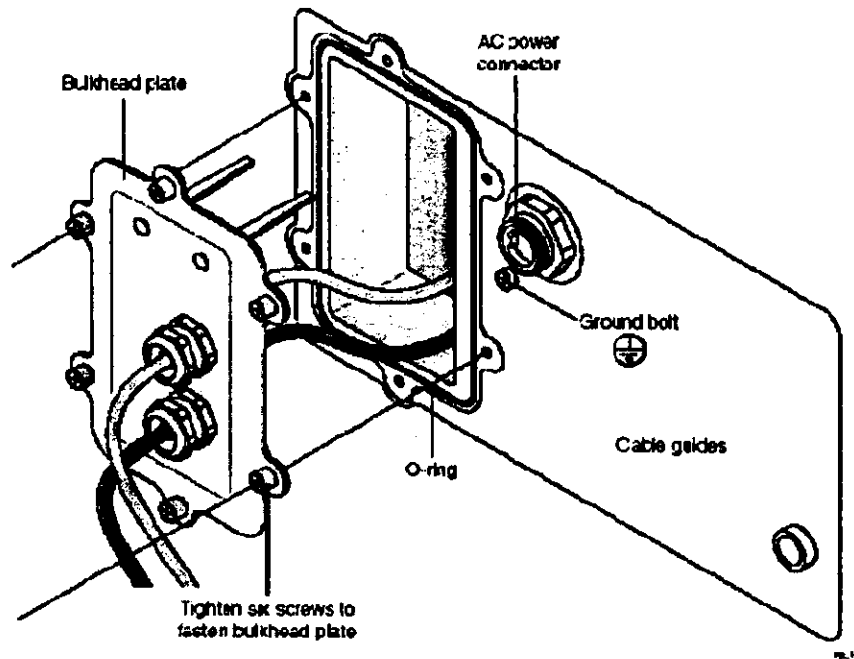

5. Run raw-terminated, shielded Category 5 Ethernet cable appropriate for outdoor use through the Tropos 5210 access cover bulkhead openings, allowing sufficient length to terminate the cables without causing crowding in the connection area.
6. Install (Terminate) cable with a shielded RJ-45 connector, paying careful attention wiring diagram and connect to the Powered LAN port inside the Tropos 5210.

Inside Tropos radio, connect CAT 5 to LAN port

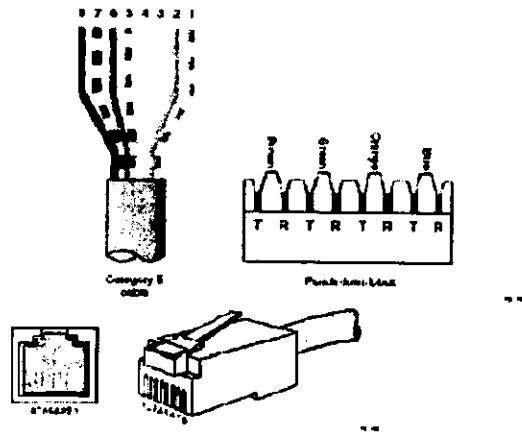
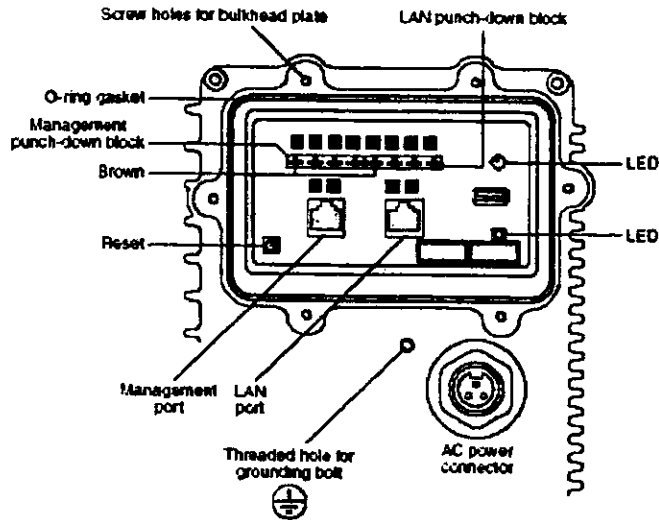

Table 3 RJ45 Pin Descriptions for Data Connection

Pin	T/R	Signal	Color	Description
1	-	TXD-	Orange-White	TX Data 10/100BaseT
2	R	TXD+	Orange	TX Data 10/100BaseT
3	-	RXD-	Green-White	RX Data 10/100BaseT
4	R	POE+	Blue	Power Output (3, 12, 24, 48, 100V)
5	-	POE-	Blue-White	Power Output (3, 12, 24, 48, 100V)
6	R	RXD+	Green	RX Data 10/100BaseT
7	-	POE-	Brown-White	Power Output (3, 12, 24, 48, 100V)
8	R	POE+	Brown	Power Output (3, 12, 24, 48, 100V)

7. Properly secure the Access Cover, mount the Tropos 5210 into the sun shield.
8. Connect the other end of the Category 5 cable to the Canopy SM unit
9. Reconnect the Tropos Power and confirm that power to the Tropos 5210 and the Canopy SM unit comes on.
10. Align the Canopy SM to AP tower per instructions on work order
11. Make Tropos 5210 and Canopy SM ready for use and secure all covers and cable connections
12. Water proof all cable connection points with approved weatherproofing tape, and secure all cables with approved cable ties.
13. Re-Verify proper street light operation by covering the photocell.
14. Measure the radio height, take two pictures and clean up any trash around installation site.

Inspection List

INSPECTION LIST			
1. Cordon proper safety area	Yes <input type="checkbox"/>	No <input type="checkbox"/>	
2. Confirm you are at the right location and the pole is fit for use	Yes <input type="checkbox"/>	No <input type="checkbox"/>	
3. Record Pole ID	Yes <input type="checkbox"/>	No <input type="checkbox"/>	
4. Record GPS LAT/LONG	Yes <input type="checkbox"/>	No <input type="checkbox"/>	
5. Record Address, Street, X-Street	Yes <input type="checkbox"/>	No <input type="checkbox"/>	
6. Record Type of Install	Yes <input type="checkbox"/>	No <input type="checkbox"/>	
7. Confirmed light works prior to voltage measurement at photo cell socket	Yes <input type="checkbox"/>	No <input type="checkbox"/>	
8. Back plate and sun shield are properly mounted and level	Yes <input type="checkbox"/>	No <input type="checkbox"/>	
9. If Gateway/SM location, Canopy mounting bracket properly installed	Yes <input type="checkbox"/>	No <input type="checkbox"/>	
10. Record Serial Numbers and MAC Addresses	Yes <input type="checkbox"/>	No <input type="checkbox"/>	
11. Tropos 5210 Antennas are secure and weatherproofed	Yes <input type="checkbox"/>	No <input type="checkbox"/>	
12. If a Gateway/SM - ported access cover and cables properly installed	Yes <input type="checkbox"/>	No <input type="checkbox"/>	
13. Tropos 5210 radio unit properly installed in mount	Yes <input type="checkbox"/>	No <input type="checkbox"/>	
14. Canopy SM unit is mounted and cabled	Yes <input type="checkbox"/>	No <input type="checkbox"/>	
15. Tropos Radio power cable properly connected to radio	Yes <input type="checkbox"/>	No <input type="checkbox"/>	
16. Photo cell and power adaptor properly installed on street light	Yes <input type="checkbox"/>	No <input type="checkbox"/>	
17. Verify all power indicator LED are properly illuminated	Yes <input type="checkbox"/>	No <input type="checkbox"/>	
18. Canopy SM antenna properly aligned per work order	Yes <input type="checkbox"/>	No <input type="checkbox"/>	
19. Verify all covers are in place and all connections weather proofed	Yes <input type="checkbox"/>	No <input type="checkbox"/>	
20. Secure all cables with approved tie wraps	Yes <input type="checkbox"/>	No <input type="checkbox"/>	
21. Re-Verify street light operates by covering photocell	Yes <input type="checkbox"/>	No <input type="checkbox"/>	
22. Measure and Record Radio height and verify 2 pictures were taken	Yes <input type="checkbox"/>	No <input type="checkbox"/>	
23. Trash cleaned up and removed upon completion	Yes <input type="checkbox"/>	No <input type="checkbox"/>	
24. Comments: Extra information			
		Job Completed	
		Yes <input type="checkbox"/> No <input type="checkbox"/>	
Technician	Phone	Date	

EXHIBIT B
NETWORK DESCRIPTION

Network Architecture

EarthLink will leverage best-of-breed technological solutions to develop the Wireless Philadelphia network. This will include the use of the Tropos 5210 802.11 Wi-Fi router to deliver Wi-Fi connectivity to end users, and the Motorola Canopy platform using license free spectrum in 5.7 GHz, 5.2 GHz and 900 MHz bands for backhaul from the Wi-Fi nodes to Access Towers. From the Access Towers, EarthLink will use a mix of high capacity point-to-point backhaul radios (14 Mbps to 400 Mbps) in various “leased” microwave bands (various bands between 6 GHz and 28 GHz) and in unlicensed spectrum bands, as well as fiber, to transport data to the EarthLink Philadelphia Backbone POP.

EarthLink has designed the Wireless Philadelphia using a layered approach, each layer

EARTHLINK CONFIDENTIAL AND PROPRIETARY INFORMATION

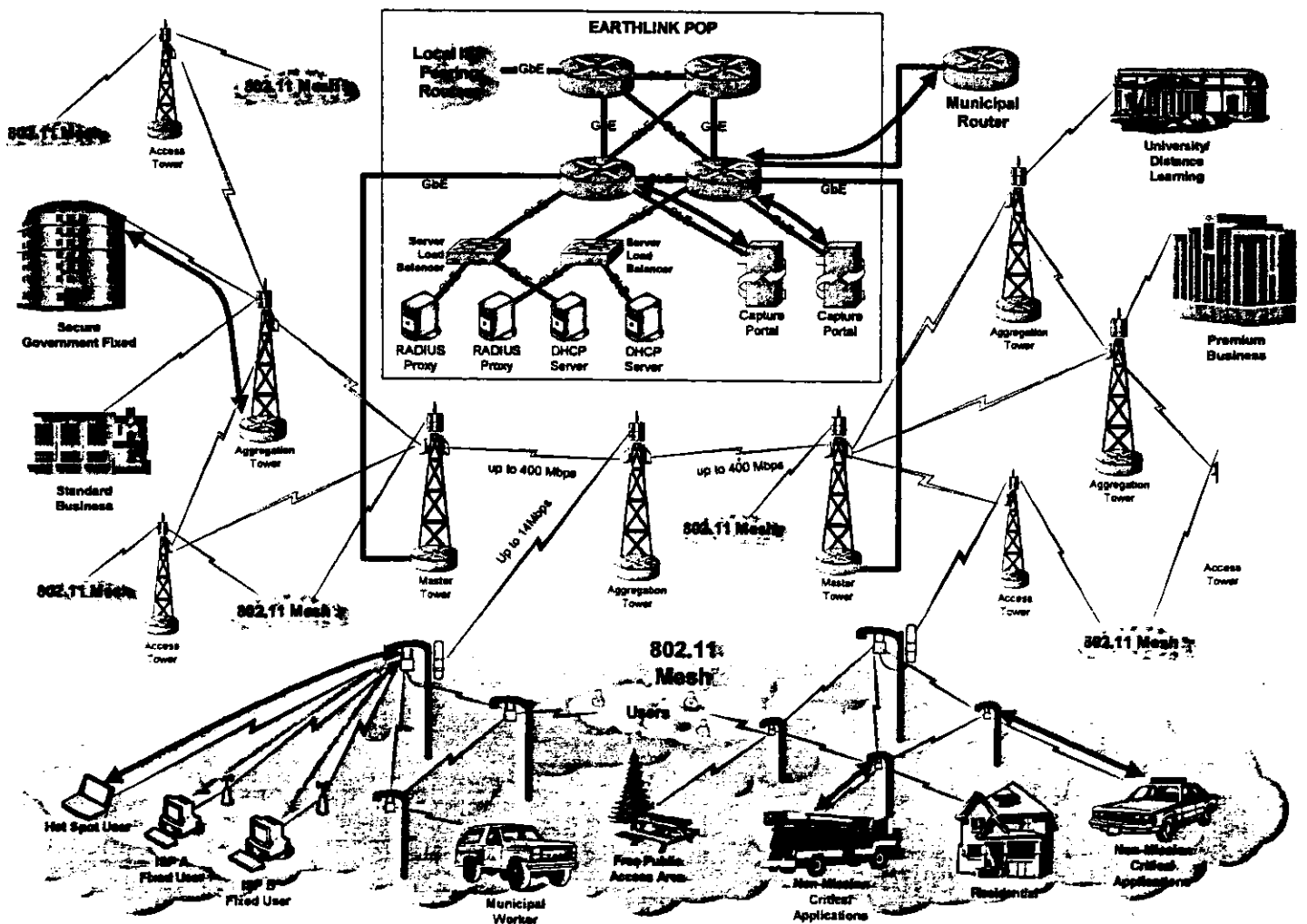

complimenting the next layer. There are three major layers:

- Backhaul Layer – includes wireless backhaul towers and fiber backhaul facilities
- Capacity Injection Layer – includes Canopy Access Points and Canopy Gateway modules which may be used to provide capacity to the Tropos nodes at lamp posts, and may also be used to provide T1 type services to government, commercial and institutional subscribers.
- Mesh Access Layer – includes the Tropos nodes and end user Wi-Fi CPE.

Layered Network Approach

EARTHLINK CONFIDENTIAL AND PROPRIETARY INFORMATION

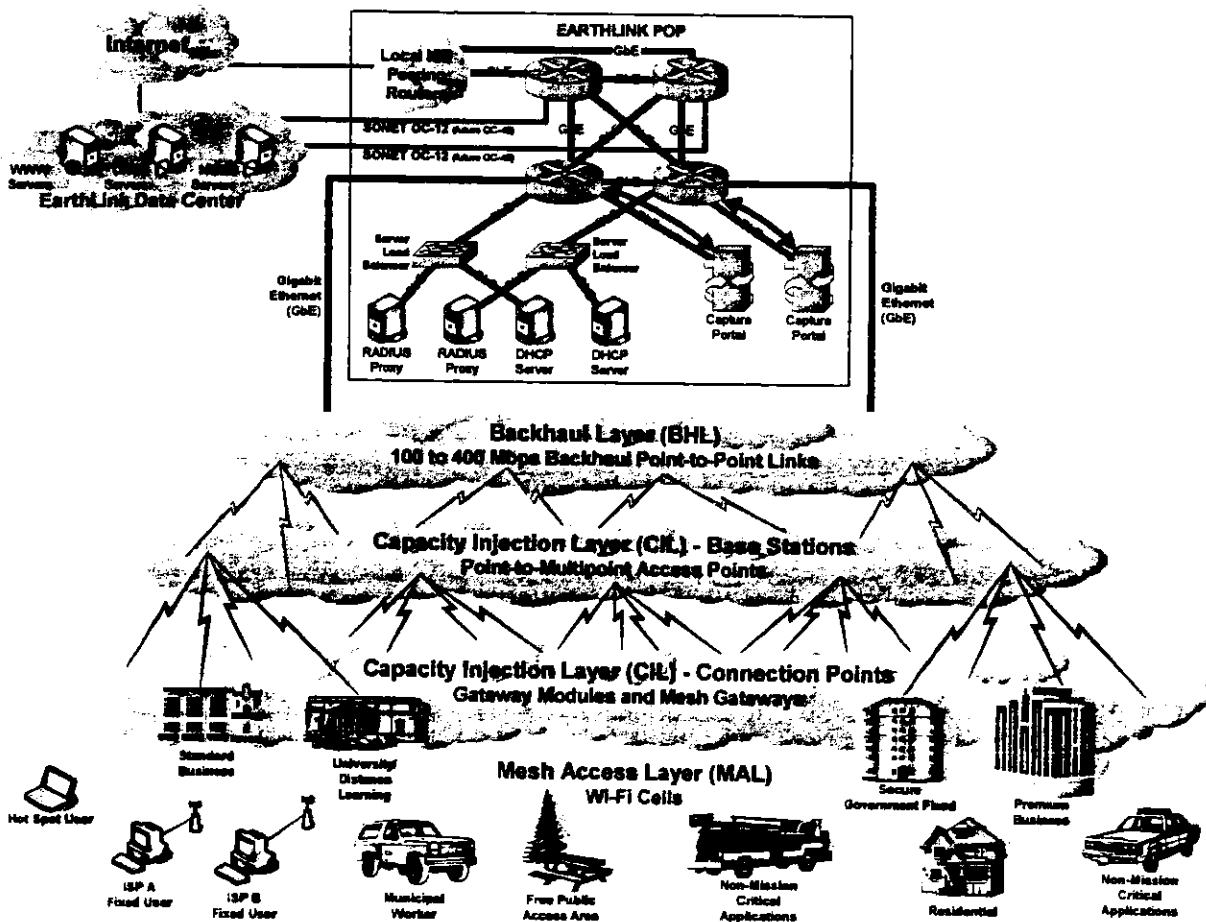

Backhaul Layer

It is estimated that 24 towers will be utilized to provide backhaul coverage throughout the network. These towers have been categorized into three different tower types, Access, Aggregation and Master towers.

The Access Towers will be equipped with two Canopy Access Point clusters and two 45 Mbps backhaul radios. The backhaul radios will interconnect the Canopy Access Point clusters to two separate Aggregation or Master Towers for path diversified redundancy.

Access Towers supporting only traffic aggregated directly from Canopy Gateway Modules and Wi-Fi nodes will have two 45 Mbps backhaul links. In case of a complete failure of an Access Tower, Wi-Fi traffic will route through the underlying wireless mesh to the nearest working tower. In order to maintain high capacity for services, Access Towers on which Fixed Wireless services are provisioned (such as the Secure Government Fixed data T1 replacement product) will be configured with appropriately sized point-to-point wireless backhaul links (up to 400 Mbps).

Aggregation Towers will aggregate the traffic from the Access Towers. Aggregation Towers will be equipped with two or more line-of-sight microwave links providing up to 400 Mbps of throughput to the Master Towers. Each Aggregation Tower is limited to 3 backhaul radios due to required channel separation. These links will be configured in rings for full network path redundancy, with path selection performed by an external router at each Aggregation Tower.

Master Towers will connect directly to the EarthLink Philadelphia Backbone POP via terrestrial fiber links.

Capacity Injection Layer

The Capacity Injection Layer is comprised of Motorola Canopy Access Point clusters and Canopy Gateway Modules. The Canopy Gateway Modules feed the Mesh Access Layer nodes. The Gateway Modules will be collocated with a Tropos 5210 Wi-Fi node at specific points throughout the network. The Capacity Injection Layer will make use of three different frequencies in the unlicensed RF bands.

- 900 MHz: 902 MHz – 928 MHz
- 5.2 GHz: 5.250 GHz – 5.350 GHz
- 5.7 GHz: 5.725 – 5.850 GHz

The 5.2 GHz frequency band will be leveraged to the maximum extent possible for the Wireless Philadelphia network. The 5.7 GHz band will be used as a compliment to the 5.2 GHz backhaul equipment. Since the Canopy 5.7 GHz Access Points use the same frequency range as some of the high capacity backhaul modules, the use of 5.7 GHz on the Capacity Injection Layer will be determined by the Backhaul Layer requirements in the final design phase to ensure that there is no interference between the Backhaul Layer and the Capacity Injection Layer.

The City of Philadelphia represents a large cross section of terrain challenges. To accommodate for these challenges and to provide the level of coverage required, EarthLink will also employ wide scale use of the Motorola Canopy 900 MHz product line. Since 900 MHz provides non-line of sight coverage, the network will be able to reach areas that might otherwise remain unreachable with wireless links at 5.2 GHz or 5.7 GHz.

Mesh Access Layer

The Mesh Access Layer will be equipped with outdoor high performance Tropos 5210 Wi-Fi nodes. All of these nodes can be easily configured as nodes or Gateway Hosts depending on the needs of the network. A node configured as a Gateway Host is attached to a data cable connected to the Canopy Gateway Module, while a stand alone node operates completely wirelessly, sending and receiving packets to end user CPE as well as forwarding packets to other Wi-Fi nodes.

The design for the Wireless Philadelphia network will utilize as low as a 3:1 ratio of nodes to Gateway Modules. In other words, there will be much as one gateway to every three nodes. This 3:1 ratio will result in an estimated 4,050 Tropos radios and 1,350 Canopy Gateway Modules that will be deployed throughout the network.

For connectivity, every Tropos Gateway Host will be collocated with a Canopy Gateway Module. These units will leverage the existing City of Philadelphia street light and pole infrastructure.

Network Design

To achieve outdoor and indoor coverage requirements, EarthLink will deploy up to 30 Tropos 5210 802.11 b/g Wi-Fi radios per square mile.

EarthLink will implement one Motorola Canopy Gateway Module to backhaul data for as little as every three Tropos Wi-Fi nodes, which will reduce the network's reliance on the Wi-Fi mesh to provide as much backhaul between the nodes. It is expected to allow traffic to be transported as quickly as possible onto the high capacity backhaul network, reducing latency and mitigating the decreases in bandwidth typically observed by end users as more node-to-node hops are required to reach the gateway.

EarthLink has specified the use of powerful 200mW CPE with high gain +12 dBi directional antennae. The use of this equipment will help to assure indoor coverage and the bandwidth requirements as specified by the requirements.

Network Assumptions Used in Preliminary Design

The following represent the network assumptions taken into consideration for the preliminary design. EarthLink retains the right to modify the network designs with approval of the Steering

Committee and exact equipment volumes and ratios may be less than stated, if the required SLAs are still able to be achieved. Listed below are the assumptions used for this analysis.

- Coverage area is 135 square miles
- 90% indoor coverage target
- 95% outdoor coverage target
- Up to 30 Tropos radios per square mile
- One Motorola Canopy Gateway Module for every 3 Tropos nodes
- Up to 4,050 Tropos nodes required for the network deployment
- Up to 1,350 Gateway Modules required for the network deployment
- 24 towers required for deployment based on visual inspection
 - 14 Access Towers
 - 4 Aggregation Towers
 - 6 Master Towers
- Each tower will be equipped with 2 full Access Point clusters
- 312 total Access Points will be deployed
- 3.25 Gateway Modules will be associated to every Access Point
- Each cluster requires the use of a Cluster Management Module (CMM)
- Access Towers will have two 45 Mbps backhaul units
- A high capacity (up to 400 Mbps) backhaul radio will be added to Access Towers
- Aggregation Towers have one (up to 400Mbps) line-of-sight radio for backhaul
- Aggregation Towers will be equipped with an external device such as a router or switch to aggregate traffic between the radios
- Master Towers will have terrestrial fiber connectivity to the POP
- A mix of 900 MHz, 5.2 GHz and 5.7 GHz equipment will be used in the network

Overview of Network Infrastructure Elements

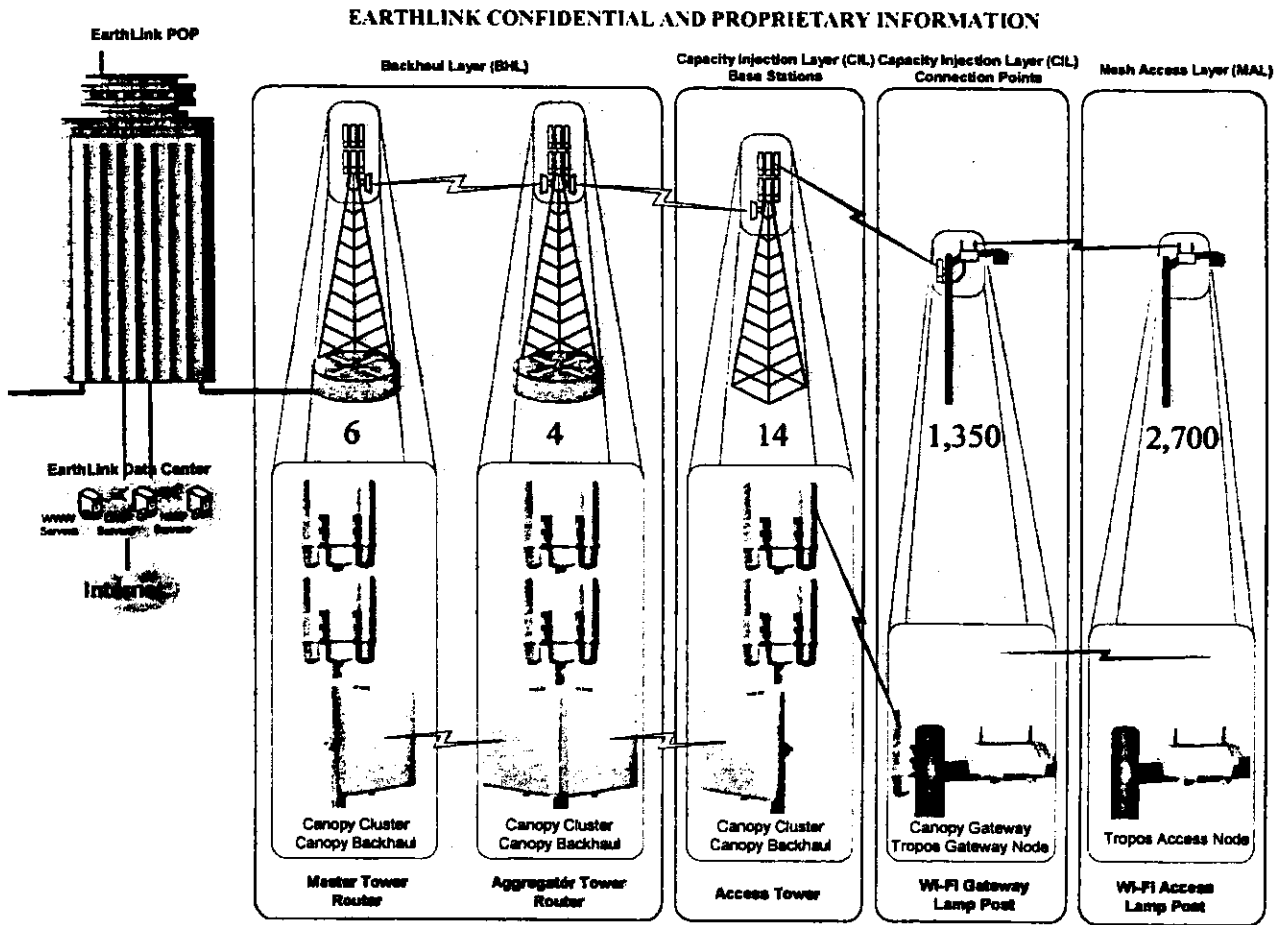

Motorola Canopy Hardware Solution

The Canopy system, Motorola’s wireless broadband solution, will be used to extend connectivity to the Mesh Access Layer in EarthLink’s network design. The Canopy products utilized will include those in the 900 MHz, 2.4 GHz, 5.2 GHz and 5.7 GHz frequency bands.

EarthLink’s design for the Wireless Philadelphia network makes use of products in the 5.2 GHz and 5.7 GHz frequency bands to provide backhaul capacity for the Wi-Fi mesh layer of the network and augments the system with products in the 900 MHz frequency bands to extend coverage in difficult to reach areas.

The Canopy system represents a hardened, outdoor, high-speed wireless solution. Canopy is designed to be reliable in operation; there are no moving parts, a single unit and no odd connectors. The Canopy system has a mean time between failures of 45 years. Significant features include:

- GPS synchronization that ensures that Canopy does not “interfere with itself”.
- Carrier to Interference (C/I) ratio as low as 2dB, compared to other solutions C/I ratios of typically 7 to 25dB. Canopy is extremely tolerant to interference from other sources as well as from other Canopy radios in the network.
- The Canopy system is highly scalable and requires no elaborate frequency planning and coordination.
- The Canopy system uses industry proven authentication and encryption technologies including DES and optional AES solutions providing the most secure wireless network available in the industry.
- The Canopy hardware draws little power and its packaging is unobtrusive.
- The installation of the equipment is straightforward with the 60-degree antennas being easily aligned, aided by the built-in visual feedback installation indicators.

These characteristics will facilitate the initial deployment and subsequent network expansions. The Canopy system’s low cost also makes it suitable for serving Secure Government Fixed as well as Premium Residential and Small Business consumers with data rates in excess of today’s DSL and cable data networks. It is also an excellent system for serving enterprise properties, such as schools, hospitals and small business campuses.

The Canopy Advantage platform is based on software defined radio technology that removes the constraints imposed by traditional hardware designs or chip sets. The Canopy Advantage platform can support new functionality and enhancements via software upgrades. EarthLink also selected the Canopy Advantage platform because it provides the industry’s highest level of interference tolerance, security, scalability, signal reliability and ease of installation.

- High Performance: Effectively reduces latency by one-third (from approximately 20 milliseconds to 5 to 7 milliseconds).
- Speeds: Delivers data rates in excess of today’s DSL and cable networks of 7 Mbps. In addition, when Advantage Gateway Modules and Access Points are used together, throughput actually doubles yet again and can reach up to 14 Mbps to a single device.
- Quality of Service: Enables the Wireless Philadelphia network to provide differentiated levels of service using Committed Information Rate (CIR) and Maximum Information Rate (MIR).

- **Multi-Services Platform**: An ATM frame structure uses small frame sizes which reduces retransmission times and provides for low latency, a critical component supporting the vision of future high quality services such as VoIP and online gaming over the Wireless Philadelphia network.
- **Seamless Integration**: Any legacy Canopy Modules can be upgraded, via software download, to take advantage of the benefits of the Canopy Advantage platform.

Motorola Canopy 5.7 GHz Advantage Gateway Module Specifications

Description	5.7 GHz Advantage Gateway Module
Canopy Part Number	5750SM
Market Availability	North America, Latin America, Asia
Signaling Rate	20 Mbps Maximum
Typical LOS Range	2 Mile (3.2 km) max
Typical Aggregate Useful Throughput	14 Mbps to 1 Mi (1.6
Frequency range of band	ISM 5725-5850 MHz
Non-overlapping Channels	6
Channel Width	20 Mhz
Channel Spacing	every 5 MHz
Modulation Type	High Index 2-level Frequency Shift Keying (FSK) optimized for interference rejection
Encryption	DES capable
Latency	5 - 7 msec
Carrier to Interference ratio (C/I)	-3dB @ 10 Mbps, -10dB @ 20 Mbps at -65dBm
Nominal Receiver Sensitivity (dbm typical)	-86 dB
Antenna Gain (dB)	7 dB
EIRP (dB)	30 dB
Equivalent Isotropic Radiated Power (EIRP)	1W
DC Power (typical)	0.3 A @ 24 VDC = 7.2 W
Antenna Beam Width	3 dB antenna beam width 60 degrees, Azimuth and Elevation
Temperature	-40° C to +55° C (-40° F to +131° F)
Wind Survival	190 km/hr (118 miles/hr)
Dimensions	11.75 in H x 3.4 in W x 3.4 in D (29.9 cm H x 8.6 cm W x 8.6 cm D)
Weight	45 kg (1 lb)
Access Method	Time Division Duplexing/Time Division Multiple Access (TDD/TDMA)
Interface	10/100 Base T, half/full duplex. Rate auto negotiated (802.3 compliant)
Protocols Used	IPV4, UDP, TCP, ICMP, Telnet, HTTP, FTP, SNMP
Network Management	HTTP, TELNET, FTP, SNMP Version 2c
FCC ID	ABZ89FC5804
Industry Canada Certification Number	109W-5700
NYCE	0202CE08128

Motorola Canopy 5.2 GHz Advantage Gateway Module Specifications

Description	5.2 GHz Advantage Gateway Module
Canopy Part Number	5250SM
Market Availability	North America
Signaling Rate	20 Mbps Maximum
Typical LOS Range	2 Mi Max
Typical Aggregate Useful Throughput	14 Mbps Maximum
Frequency range of band	U-NII 5250-5350 MHz
Non-overlapping Channels	3
Channel Width	20 MHz
Channel Spacing	every 5 MHz
Modulation Type	High Index 2-level Frequency Shift Keying (FSK) optimized for interference rejection
Encryption	DES capable
Latency	5 - 7 msec
Carrier to Interference ratio (C/I)	-3dB @ 10 Mbps, -10dB @ 20 Mbps at -65dBm
Nominal Receiver Sensitivity (dbm typical)	-86 dBm
Antenna Gain (dB)	7 dB
EIRP (dB)	30 dBm
Equivalent Isotropic Radiated Power (EIRP)	1W
DC Power (typical)	0.3 A @ 24 VDC = 7.2 W
Antenna Beam Width	3 dB antenna beam width 60 degrees, Azimuth and Elevation
Temperature	-40° C to +55° C (-40° F to +131° F)
Wind Survival	190 km/hr (118 miles/hr)
Dimensions	11.75 in H x 3.4 in W x 3.4 in D (29.9 cm H x 8.6 cm W x 8.6 cm D)
Weight	45 kg (1 lb)
Access Method	Time Division Duplexing/Time Division Multiple Access (TDD/TDMA)
Interface	10/100 Base T, half/full duplex. Rate auto negotiated (802.3 compliant)
Protocols Used	IPv4, UDP, TCP, ICMP, Telnet, HTTP, FTP, SNMP
Network Management	HTTP, TELNET, FTP, SNMP Version 2c
CC ID	ABZ89FC3789
Industry Canada Certification Number	109W-5200
NYCE	0202CE08128

Motorola Canopy 900 MHz Gateway Module Specifications

Description	900 MHz SM Connectorized (External antenna)
Canopy Part Number	9000SMC
Market Availability	North America, South America, Asia
Signaling Rate	6 Mbps maximum
Typical LOS Range	30 Miles (64 km)
Typical Aggregate Useful Throughput	4 Mbps maximum
Frequency range of band	ISM 902-928 MHz
Non-overlapping Channels	3
Channel Width	8 MHz
Channel Spacing	1 MHz
Modulation Type	High Index 2-level Frequency Shift Keying (FSK) optimized for interference rejection
Encryption	DES capable
Latency	< 15 msec
Carrier to Interference ratio (C/I)	-3dB @ 3 Mbps, -10dB @ 6 Mbps at -70dBm
Nominal Receiver Sensitivity (dbm typical)	-90 dB
Antenna Gain (dB)	varies
EIRP (dB)	36 dB
Equivalent Isotropic Radiated Power (EIRP)	4 W
DC Power (typical)	0.3 A @ 24 VDC = 7.2 W
Antenna Beam Width	Connectorized 60 degree beam width azimuth and 35 degree elevation ~12.5 dBi

Mean Time Between Failure (MTBF)	40 yr
Temperature	-40° C to +55° C (-40° F to +131° F)
Wind Survival	190 km/hr (118 miles/hr)
Dimensions	11.75 in H x 3.4 in W x 3.4 in D (29.9 cm H x 8.6 cm W x 8.6 cm D) Antenna Varies
Weight	45 kg (1 lb), antenna varies.
Access Method	Time Division Duplexing/Time Division Multiple Access (TDD/TDMA)
Interface	10/100 Base T, half/full duplex. Rate auto negotiated (802.3 compliant)
Protocols Used	IPv4, UDP, TCP, ICMP, Telnet, HTTP, FTP, SNMP
Network Management	HTTP, TELNET, FTP, SNMP Version 2c
FCC ID	ABZ89FC5809

Tropos Mesh Wi-Fi Hardware and Software Solution

In the Mesh Wi-Fi layer, EarthLink will utilize the Tropos 5210 Outdoor MetroMesh Router node. The Tropos platform combines sophisticated mesh routing intelligence to optimize throughput in a metro-scale Wi-Fi mesh environment, with carrier-grade centralized element management and a hardware platform with top grade Wi-Fi link budgets.

The Tropos MetroMesh OS, including the Tropos Predictive Wireless Routing Protocol (PWRP), is a scalable mesh routing algorithm. The Tropos 5210 node, utilizing the embedded PWRP, creates a self-organizing and self-healing wireless mesh, and intelligently selects the optimum data path to the wired network. Because the MetroMesh OS and PWRP never require more overhead than 5% of available bandwidth, EarthLink can easily scale the Wireless Philadelphia network to many thousands of nodes without any client throughput or network capacity degradation.

The Tropos software, management tools and hardware combine to enable the operation of multiple independent networks on a single infrastructure. EarthLink can enable individual user communities to operate independently, segregating information access, billing and access levels.

The rugged and weatherized Tropos 5210 is NRTL certified for outdoor installation. The 5210 node requires only power and can be deployed anywhere power is available, including buildings or lamp posts. Each Tropos node provides wireless connectivity to standard 802.11 b/g clients.

Tropos solution features include:

- Standard IEEE approved and supported Wi-Fi (802.11 b and 802.11 g): Support for industry standard 802.11 CPE devices including laptops and PDAs without any proprietary hardware required. Standard components are utilized in all aspects of the system.
- Carrier-Class Reliability: The proposed solution will deliver 99.9% uptime. The network design includes mesh technology supporting optimized routing, self-organizing mesh routers, automatic failure recovery and an SNMP-based element manager.
- Scalability: The Tropos 5210 is a 1 Watt mesh Wi-Fi router with very high receive sensitivity at -98 dBm.
- Coverage: Initial estimates of coverage, based on commercially available map source information and density analysis, suggest that the equipment should provide over 90% indoor coverage.
- Quality of Service (QoS): To guarantee complete, carrier-class coverage, Tropos nodes will be installed with overlapping coverage areas, providing resiliency from interference, wired or wireless network failure and other environmental disruptions.
- High Performance: The network proposed will support end user bandwidth over 1 Mbps.

- **Security:** The system proposed supports WEP (not recommended), WPA, AES, MAC Address Filtering and Virtual Private Network (VPN) Security.

Tropos 5210 MetroMesh Router Technical Specifications

<p>Wireless</p>	<ul style="list-style-type: none"> • IEEE 802.11b/g • Frequency band: 2.4-2.483 GHz • Modulation: 802.11g - OFDM (64-QAM, 16-QAM, QPSK, BPSK) • 802.11b - DSSS (DBPSK, DQPSK, CCK) • TX Power: <ul style="list-style-type: none"> - Standard 14dBm-24dBm (EIRP) factory-set in 1dB units - High-Power 26dBm-36dBm (EIRP) factory-set in 1dB units • 7.4dBi Omni directional antennas • Media Access Protocol: CSMA/CA with ACK • Transmit and Receive diversity • RX Sensitivity: <ul style="list-style-type: none"> - -100dBm @ 1 Mbps - -94dBm @ 5.5 Mbps - -92dBm @ 11 Mbps - -95dBm @ 6 Mbps - -93dBm @ 12 Mbps - -90dBm @ 18 Mbps - -87dBm @ 24 Mbps - -84dBm @ 36 Mbps - -79dBm @ 48 Mbps - -77dBm @ 54 Mbps
<p>Networking</p>	<ul style="list-style-type: none"> • TCP and VPN session persistent roaming • Full 802.11b/g client compatibility • NAT support • Layer 2 and Layer 3 support • DHCP Server and Relay • Sub-interface support • Ethernet port
<p>Management</p>	<ul style="list-style-type: none"> • HTTPS to on-board configuration management tools • Secure local and remote configuration via HTTPS • SNMP V2c • Tropos MIB • Browser-based management tool • Simple configuration save and restore • Network & client monitoring and statistical capture features
<p>Security</p>	<ul style="list-style-type: none"> • WPA - (64, 128, 152-WEP with TKIP) • Multiple ESSIDs • Full VPN compatibility • VPN filtering—rejects non-VPN traffic • MAC address access control lists • HTTPS only to on-board management tools • AES encryption of wireless routing • Packet filtering • ESSID suppression
<p>Environmental Specifications</p>	<ul style="list-style-type: none"> • Operating temperature range: -40°C to 55°C • Storage temperature range: -40°C to 85°C • Weather rating: IP67 weathertight • Wind survivability: >165 mph • Wind loading (165 mph): <1024 Newtons • MIL-STD-810F 509.4 Salt Fog rust resistance compliant • Shock & vibration: ETSI 300-19-2-4 spec T41.E class 4M3 • Transportation: ISTA 2A

Optional Battery Back-Up	<ul style="list-style-type: none"> • Factory Installed Li-Ion battery • Back-up power 4-12 hours typical
Optional Accessories	<ul style="list-style-type: none"> • Power Cables • Street light NEMA photo-electric control power tap 90-480 V • AC, 2 wire 4 ft. power cable • Street light NEMA photo-electric control power tap 90-480 V AC, 2 wire 20 ft. power cable • Electrical power cord, US/Canada 120 VAC, 15 A, 3 prong 6 ft. or 30 ft. • CAT5 building entrance data protection; network protection unit
Package Contents	<ul style="list-style-type: none"> • Tropos 5210 • Mounting bracket and accessories • Hardware Installation and Quick Start Guides
Approvals	<ul style="list-style-type: none"> • FCC CFR 47 Part 15, Class B • Industry Canada RSS 210 • Taiwan DGT LP0001/LP0002 • VCCI class B • ARIB STD-T66 • EN 301 489-17 • EN 300 328 • EN 60 950 • IEC 950 • UL 60950-1 • CSA 22.2 No. 950 • UL 579/IEC 60529 IP67 rated for outdoor use • UL 1449/IEC 60 664-1 • CE
Hardware Specifications	<ul style="list-style-type: none"> • Autosensing 10/100BaseT Ethernet • Power input: • 90-480VAC 50/60Hz single and split-phase ANSI/IEEE C62.41 • category C3 integrated branch circuit protection • AC power consumption: 18 W typical • Power over Ethernet power sourcing capability: • 12Vdc @ 14W, 24Vdc @ 12W, 48Vdc @ 10W output • Power-on and network status lamp: Green/Red • Dimensions (w/o mounting brackets or antennas): 13.00 in (33.02 cm) wide x 8.00 in (20.32 cm) deep x 5.3 in (13.50 cm) high • Weight: 14 lbs (6.40 kg) max., with mounting brackets
Protection Circuits	<ul style="list-style-type: none"> • Antenna Protection: $\leq 0.5\mu\text{J}$ for 6kV/3kA @ 8/20μs Waveform • Electrical Protection: <ul style="list-style-type: none"> - ANSI/IEEE C62.41, UL 1449-2nd ed., 10kA @ 8/20 μs Wave form, 36kA per phase, L-L, L-N, L-PE - EN61000-4-5 Level 4 AC Surge Immunity - EN61000-4-4 Level 4 Electrical Fast Transient Burst Immunity - EN61000-4-3 EMC Field Immunity • Data Protection: EN61000-4-2 Level 4 ESD Immunity
Warranty	<ul style="list-style-type: none"> • One (1) year on parts and labor; return to point of purchase • Optional standard and premium support packages available

High Capacity Wireless Backhaul Components

EarthLink is in the process of evaluating several vendors of high capacity wireless backhaul equipment, in the unlicensed 5.7 GHz band, as well as in leased / licensed point-to-point 6 GHz, 11 GHz, 18 GHz, 23 GHz, 24 GHz, 26 GHz or 28 GHz bands. These radios will provide the 45

Mbps to 400 Mbps backhaul connections from the Access Towers to the Aggregation Towers to the Master Towers, as specified in the EarthLink network design.

Proof of Concept

The proof of concept network validation will utilize the network throughput, coverage and mobility design control documents as the test criteria for the proof of concept acceptance. The test area will cover more than 10 square miles and less than 20 square miles and will include an estimated 450 Tropos 5210 Wi-Fi nodes and approximately 150 Motorola Canopy Gateway Modules to backhaul the traffic from the Wi-Fi mesh to the access towers. A minimum of two separate tower locations will feed the mesh network to provide backhaul route diversity.

Design Control Documents (DCDs) will be created for the Proof of Concept zone (and subsequent zones). The DCDs will include a detailed design for each zone and details on Acceptance Testing processes and methods to measure the Performance Criteria identified in the Requirements. Final Service Level Agreements (SLAs) will be created following the completion of Acceptance Testing and appended to the definitive agreement.

EXHIBIT C
FORM OF LETTER OF CREDIT

FORM OF LETTER OF CREDIT

Irrevocable Letter of Credit No. _____

Date

Beneficiary's Name

Beneficiary's Address

Account Party: **EarthLink, Inc.**
Beneficiary: City of Philadelphia
Amount: \$500,000.00 U.S. Dollars

Ladies and Gentlemen:

A. We hereby issue this irrevocable, letter of credit number _____ (the "Credit") in your favor, payable in immediately available funds in one or more draws of any sum or sums not exceeding in the aggregate Five Hundred Thousand Dollars (\$500,000.00), by your draft(s) drawn on us at sight presented at our counters together with a signed certificate stating the following:

"The undersigned, the Commissioner of the Streets Department ("Streets Department") of Beneficiary, hereby certifies that: (1) EarthLink has not met its obligation to remove Communications Equipment from the Street Lights pursuant to the Street Light Use Agreement dated _____ between EarthLink, Inc. and the Philadelphia Authority for Industrial Development (the "Agreement") and is entitled to the amount drawn hereunder pursuant to the terms of Section 8.5 of that Agreement; or (2) EarthLink has notified the City that the Credit will expire within thirty (30) days."

We will accept such statement as conclusive, binding and correct without having to investigate or having to be responsible for the accuracy, truthfulness, correctness or validity thereof, and notwithstanding the claim of any person to the contrary.

Drafts presented under this Credit shall specify the number of this Credit as set forth above and shall be presented on or before the expiration date hereof.

B. This Credit is assignable and transferable and may be transferred one or more times, without charge, upon our receipt of your written notice that an agreement to transfer or assign this Credit has been executed.

C. This Credit shall be automatically renewed from year to year commencing on the first anniversary of the date hereof, unless and until we shall give thirty (30) days prior written

notice to you, by certified mail, return receipt requested, at the address set forth above, of our intent not to renew this Credit at the expiration of such thirty (30) day period. During such thirty (30) day period, this Credit shall remain in full force and effect and Beneficiary may draw up to the full amount hereof when accompanied by one of the statements described in the first paragraph of this Credit.

D. Notwithstanding anything to the contrary contained herein, the letter of credit disbursement shall be limited to the amount of the removal expenses stated and reasonably documented by the Streets Department in the certification described above. After a draw request is paid by us in that amount, then the balance remaining on the letter of credit shall be available for further draws by the Beneficiary as may be required to remove other Communications Equipment not removed by EarthLink pursuant to the Agreement. In the event the Beneficiary's actual cost of removal is less than the amount stated in the Streets Commissioner's certification, or in the event the City does not use the funds drawn under the letter of credit for removal and/or storage of Communications Equipment within eighteen (18) months of drawing the funds, then the City shall promptly refund the amount of such difference to the issuer of the letter of credit, which will credit the refund to the amount that can be drawn on the letter of credit. This Credit shall be returned to EarthLink for cancellation if: (1) the City determines in its reasonable judgment that all Communications Equipment has been removed from Street Lights, and (2) the City determines in its reasonable judgment that all storage obligations of the City regarding removed Communications Equipment provided for in Section 8.5 and elsewhere in the Agreement have also terminated.

E. We hereby engage with you that drafts drawn under and in compliance with the terms of this Credit will be duly honored five (5) days after the above certification is presented to us and also delivered to EarthLink, Inc.

F. This Credit sets forth in full the terms of our undertaking and such undertaking shall not in any way be modified, amended, amplified or limited by reference to any document, instrument or agreement referred to herein, or by any document, instrument or agreement in which this Credit is referred to, or to which this Credit relates, and any such reference shall not be deemed to incorporate herein by reference any such document, instrument or agreement.

G. Except as otherwise expressly stated herein, this Credit is subject to the International Standby Practices (ISP98), International Chamber of Commerce Publication No. 590 and, to the extent not inconsistent therewith, the laws of the State of New York.

[BANK]

By: _____

Authorized Officer

EXHIBIT D

PROVISIONS REQUIRED BY CHAPTER 17-1400 OF THE PHILADELPHIA CODE

For this section of the agreement, the following terms shall have following meanings:

Applicant - a Person who has filed an application to be awarded a Non-Competitively Bid Contract.

Consultant - any Person used by Provider to assist in obtaining a Non-Competitively Bid Contract through direct or indirect communication by such Person with any City Agency or any City officer or employee, if the communication is undertaken by such Person in exchange for, or with the understanding of receiving, payment from the Provider or any other Person; provided, however, that "Consultant" shall not include a full-time employee of the Provider.

Contributions - as defined by the Pennsylvania Election Code, 25 P.S. Section 3241.

Non-Competitively Bid Contract - a contract for the purchase of goods or services to which the City or a City Agency is a party that is not subject to the lowest responsible bidder requirements of Section 8-200 of the Charter, including, but not limited to, a Professional Services Contract, and any renewal of such a contract (other than a renewal term pursuant to an option to renew contained in an executed contract).

Provider's Duties and Covenants Pursuant to 17-1400

If Provider is a City-Related Agency, as defined at Philadelphia Code Subsection 17-1401(9), Provider shall abide by the provisions of Philadelphia Code Chapter 17-1400 in awarding any contract(s) pursuant to this Agreement as though such contracts were directly subject to the provisions of Chapter 17-1200, except that the exception set forth at Subsection 17-1406(8) shall apply to Provider as if Provider were listed in that subsection.

Unless approved by the City to the contrary, any approvals required by the Philadelphia Code Chapter 17-1400 to be performed by the City Solicitor shall be performed by Provider by its General Counsel; any approvals required to be performed by the Director of Finance shall be performed by Provider by its Chief Financial Officer; and any approvals required to be performed by the Mayor shall be performed by Provider by its Executive Director.

Provider's Representations, Warranties and Covenants Pursuant to 17-1400

In accordance with Section 17-1402 of The Philadelphia Code, Provider represents on behalf of itself and its Subcontractor(s) that no contribution(s) have been made and none shall be made

during the term of this Agreement by Provider, any Subcontractor, or any party from which a contribution can be attributed to the Provider or Subcontractor, that would render the Provider or Subcontractor, as applicable, ineligible to apply for or enter into a Non-Competitively Bid Contract under the provisions of Philadelphia Code Sections 17-1404(1) and 17-1405; and that disclosures made as part of its application to receive a Non-Competitively Bid Contract contain no material misstatements or omissions. Breach of this covenant shall constitute an event of default and render this Agreement voidable at the City's option, and shall make the Provider liable for liquidated damages to the City in the amount of ten percent (10%) of the maximum payments to the Provider allowed under this Agreement, regardless whether actually paid. The City may exercise any or all of the remedies set forth in this Agreement, each of which may be pursued separately or in conjunction with such other remedies as the City in its sole discretion shall determine. No extension or indulgence granted by the City to Provider shall operate as a waiver of any of the City's rights in connection with this Agreement. The rights and remedies of the City as described in this section and as described elsewhere in this Agreement shall not be exclusive and are in addition to any other rights or remedies available to the City under this Agreement at law or in equity.

Pursuant to the attribution rules of Section 17-1405, Provider shall, during the term of this Agreement and for one year thereafter, disclose any contribution of money or in-kind assistance the Provider, Subcontractor or any Consultant has made during such time period to a candidate for nomination or election to any public office in the Commonwealth of Pennsylvania or to an individual who holds such office, or to any political committee or state party in the Commonwealth of Pennsylvania, or to any group, committee or association organized in support of any such candidate, office holder, political committee or state party, and the date and amount of such contribution.

Such disclosure shall be made on a form provided by the Department awarding this Agreement, and the form shall be signed and filed with such Department within five (5) business days of the contribution. The Department receiving the disclosure form shall forward copies to the President and Chief Clerk of Council, and to the Mayor, Finance Director, Procurement Department, and the Department of Records. The attribution rules of Section 17-1405 shall apply to determine what contributions must be disclosed under this provision as contributions of the Provider or of a Consultant.

It shall not be a violation of this section if Provider fails to disclose a contribution made by a Consultant because the Provider was unable to obtain such information from the Consultant, provided the Provider demonstrates that it used reasonable efforts to attempt to obtain such information, including, at a minimum:

- 1) Entering into a written agreement with the Consultant for such Consultant's services, before the filing of the application for this Agreement, and before the Consultant communicated with a City department or office, official or employee on behalf of the Provider;
- 2) Including in such agreement a provision requiring the Consultant to provide the Provider in a timely manner with all information required to be disclosed under the

provisions of Philadelphia Code Chapter 17-1400, and providing, in effect, that the agreement will be terminated by the Provider if the Consultant fails to provide all required information on a timely basis and that no further payments, including payments owed for services performed prior to the date of termination, will be made to the Consultant by or on behalf of the Provider as of the date of such termination;

3) Communicating regularly with the Consultant concerning the Consultant's obligations to provide timely information to permit the Provider to comply with the provisions of Philadelphia Code Chapter 17-1400; and

4) Invoking the termination provisions of the written agreement in a full and timely manner.

The Provider shall, during the Term of this Agreement and for one year thereafter, disclose the name and title of each City officer or employee who, during such time period, asked the Provider, any officer, director or management employee of the Provider, or any Person representing the Provider, to give money, services, or any other thing of value (other than a Contribution as defined in Section 17-1401) to any Person, and any payment of money, provision of services, or any other thing of value (other than a Contribution as defined in Section 17-1401) given to any Person in response to any such request. The Provider shall also disclose the date of any such request, the amount requested, and the date and amount of any payment made in response to such request.

Such disclosure shall be made on a form provided by the Department awarding this Agreement, and the form shall be signed and filed with the Department within (5) five business days after a request was made or a payment in response to a request was made, as the case may be.

The Department receiving the disclosure form shall forward copies to the President and Chief Clerk of Council, and to the Mayor, Finance Director, Procurement Department, and the Department of Records.

The above representations, warranties and covenants shall continue throughout the Term of this Agreement. In the event said representations, warranties and covenants are or become untrue or inaccurate, Provider shall promptly give notice thereof to the City, specifying the manner in which said representation, warranty or covenant is untrue or inaccurate.

Events of Default Pursuant to 17-1400

Any act, omission, or misrepresentation which renders the Provider ineligible for a City contract or renders this Agreement voidable under Philadelphia Code Chapter 17-1400 shall be an Event of Default by Provider.